



POWERSPORTS OWNER'S MANUAL



212^{cc}
GAS
MINI BIKE

READ & UNDERSTAND THIS MANUAL BEFORE RIDING!

Provincial/Municipal government have different regulations pertaining to owning and operating an off-road vehicle, learn the regulations in your area.



WARNING

Operating, servicing and maintaining a passenger vehicle or off-road vehicle can expose you to chemicals including engine exhaust, carbon monoxide, phthalates, and lead, which are known to the state of California to cause cancer and birth defects or other reproductive harm.

To minimize exposure, avoid breathing exhaust, do not idle the engine except as necessary, service your vehicle in a well-ventilated area and wear gloves or wash your hands frequently when servicing your vehicle. For more information go to www.P65Warnings.ca.gov/-passenger-vehicle

To the Owner

Congratulations on your purchase of a Drift Hero 212cc Mini Bike. This Owner's / Operator's manual will provide you information regarding safe operation, operational instructions, maintenance and care. Fully understanding this manual and following all of the instructions herein will provide the knowledge needed to have safe and enjoyable operation.

For questions regarding operation and maintenance of this Off-Road Mini Bike, please contact:

DRIFT HERO

Customer Support: 801.872.4156

E-Mail: Service@DriftHero.com

Safety - Notice to Parents

Children differ in skills, physical abilities, and judgment. Some children may not be able to operate this mini bike safely. Parents should supervise their child's use of the mini bike at all times. Parents should permit continued use only if they determine that the child has the ability to operate the mini bike safely.

***THIS MINI BIKE IS NOT A TOY AND COULD BE HAZARDOUS TO OPERATE.**

Reading the Owner's/ Operator's Manual

It is important this manual is read from cover to cover carefully by the owner and all operators. Parents should review the manual carefully with their children. Never allow anyone to operate the mini bike without first reading and understanding the Owner's/Operator's manual. This Owner's/Operator's Manual should be a permanent part of the mini bike and should remain with the vehicle at all times. The manual should also remain with the vehicle if sold.

To emphasize special important information in the manual, please note the following:



This is the alert symbol. The symbol means **ATTENTION!**, **BECOME ALERT!**, **YOUR SAFETY IS INVOLVED.**

To emphasize important safety information, the word **WARNING**, with the alert symbol, has special meaning.:



Indicates a potential hazard that could result in **SEVERE INJURY** or **DEATH** to the operator, bystander or person inspecting or repairing the unit.

To emphasize important information, the word **CAUTION** has special meaning:

CAUTION:

Indicates special precautions that must be taken to avoid damage to the unit.

To emphasize important information, the word **NOTE** has special meaning.:

NOTE:

Indicates key information to make procedures easier or clearer to understand.

 WARNING or CAUTION
The first part will identify a POTENTIAL HAZARD .
The second part will describe WHAT COULD HAPPEN if the warning or caution is ignored.

DRIFT HERO is concerned about the environment and believes in conserving and protecting all natural resources. For this reason, owners should recycle, trade in, or dispose as appropriate, oil and tires.

This manual is based on the latest product information available at the time of publication. **DRIFT HERO** has a policy of continually improving its products. Due to improvements, or other changes, there may be some discrepancies. We reserve the right to make product changes at any time, without notice and without incurring any obligation to make the same or similar changes to vehicles previously built or sold.

IMPORTANT LABELS

LOCATION

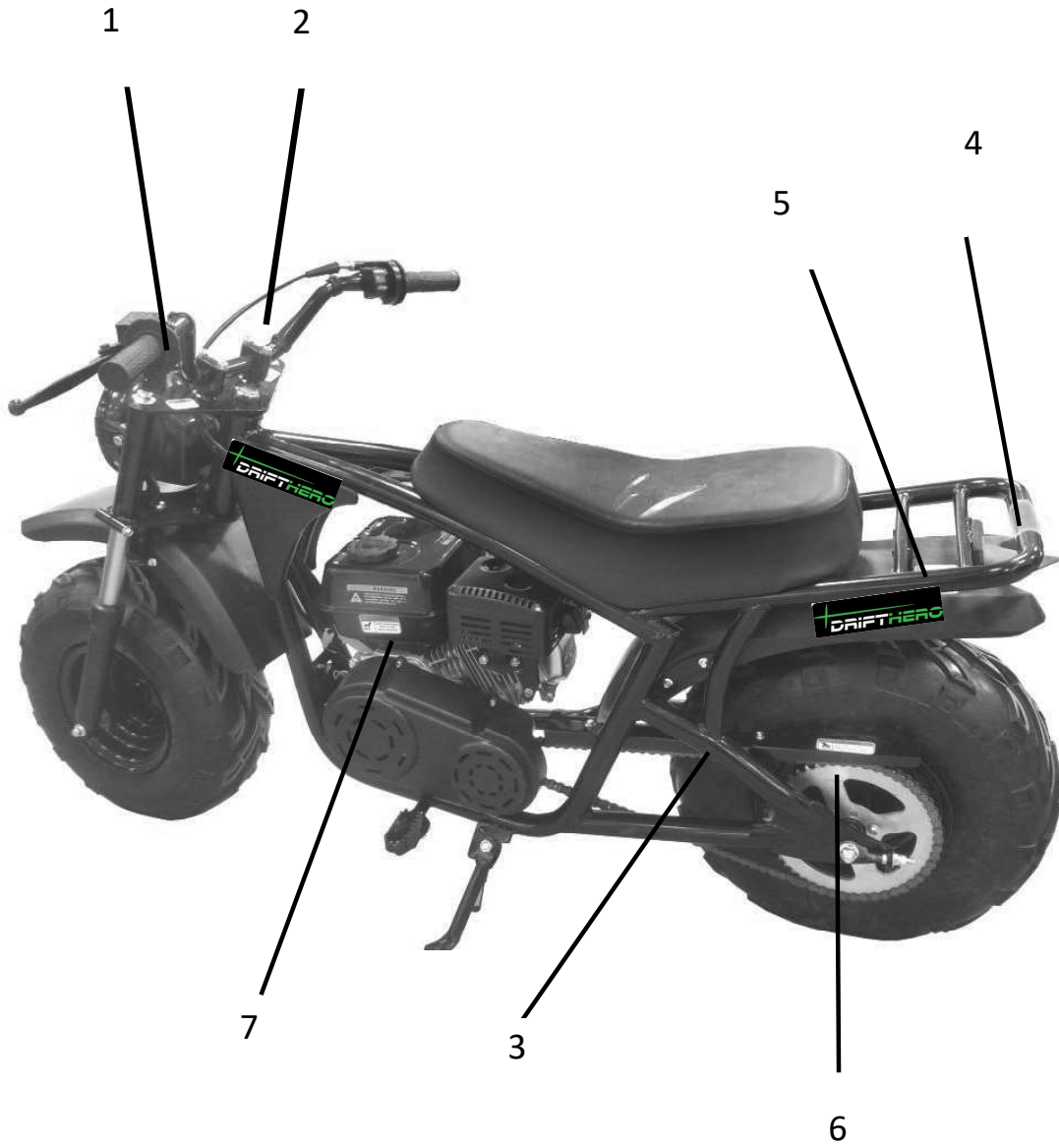

Warning Labels

1

⚠ WARNING
 THIS VEHICLE IS AN OFF-ROAD VEHICLE AND IS NOT INTENDED FOR USE ON PUBLIC ROADS/HIGHWAYS

2

⚠ WARNING
 Check the following before operating.

1. Engine oil level.
2. Lubricate and adjust drive chain if necessary.
3. Clean and Lubricate clutch.
4. Insure all Guards are in place.

4

OFF-ROAD USE ONLY

3

⚠ WARNING

This Mini Bike can cause serious injury or death if the warnings and instructions in the owner's manual and on warning labels are not followed.

Never Operate this Mini Bike:

- at speeds too fast for your skills or the conditions.
- on public roads, a collision can occur with another vehicle.
- carrying a passenger, a passenger can affect balance and control.
- while under the influence of alcohol or drugs
- with long hair or loose clothing unconstrained. Long hair and loose clothing can get caught in moving parts of the mini bike and cause serious injury or death.
- operate this mini bike in an unsafe manner by attempting stunts, jumps or wheelies. This could lead to severe injury or death.

Always:

- wear a DOT certified helmet, eye protection, gloves, over the ankle boots, long sleeve shirt and long pants.
- avoid paved surfaces, paved surfaces can adversely affect handling and control.
- keep hands and feet away from all moving parts.
- Check the throttle to ensure it works properly and "snaps back" prior to starting the mini bike.
- be seated before attempting to start the mini bike.
- continually supervise children

Recommended age 13 +

5

⚠ WARNING

Check the tires before operating to insure the proper tire pressure. Improperly inflated tires can lead to loss of control which could result in injury or death.

Cold tire pressure:
 Front: 10psi ± .5psi (69 ± 3.5kpa)
 Rear: 10psi ± .5psi (69 ± 3.5kpa)

Maximum weight capacity is 200 LBS. (91 kg)

6

⚠ WARNING

Keep hands and fingers away from chains and sprockets. Make sure guards are securely in place before operation.

7

⚠ WARNING

 **HOT SURFACES**
 Allow to cool before refueling

SAFETY

This Mini Bike is recommended for riders 13 and older.

Always wear a certified DOT motorcycle type helmet that fits properly, over the ankle boots, eye protection, gloves, long sleeve shirt and long pants while operating this mini bike.

Never allow a passenger on this mini bike. This mini bike is designed for one operator and no passengers.

Never operate this mini bike on paved surfaces and/or public roads. Pavement may cause the mini bike to become unstable. The tires on the mini bike are for off-road use only.

Always go slowly and pay attention to unfamiliar terrain. Be alert to changing terrain conditions when operating the Mini bike.

Never operate with long hair or loose clothing unconstrained. Long hair and loose clothing can get caught in moving parts of the mini bike

Never take drugs or alcohol before or during operation of this mini bike.

Never traverse, climb or go down a hill that is too steep. Avoid hills with loose or slippery terrain.

Never attempt wheelies, jumps or any other type of stunts on this mini bike.

Always follow the pre-ride inspection procedures and maintenance procedures located in this manual before use.

Always go slow on terrain that is not familiar, be alert, an obstacle could come up unexpectedly.

Always keep both hands on the handlebars and both feet on the foot pegs, doing so will help the operator be ready for unexpected situations.

Do not operate in fast flowing water. Water can affect the braking performance of the mini bike. Check braking performance after exposure to water, it may be necessary to apply the brakes allowing friction to dry out the pads.

Always Check the throttle to ensure it works properly and “snaps back” to idle prior to starting the mini bike.

DESCRIPTIONS AND PART LOCATIONS

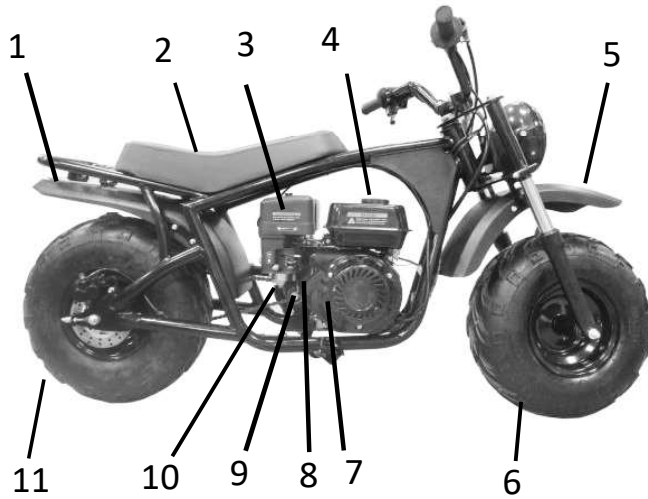

1. Rear Fender
2. Seat
3. Air filter assembly
4. Fuel Tank and Cap
5. Front Fender
6. Front Wheel
7. Starter Recoil Cord
8. Fuel Valve
9. Choke Lever
10. Carburetor
11. Rear Wheel
12. Muffler
13. Chain Guard
14. Chain adjustment bolts
15. Chain
16. Kick Stand
17. Foot Pegs
18. Clutch Cover
19. Front Shock Absorption

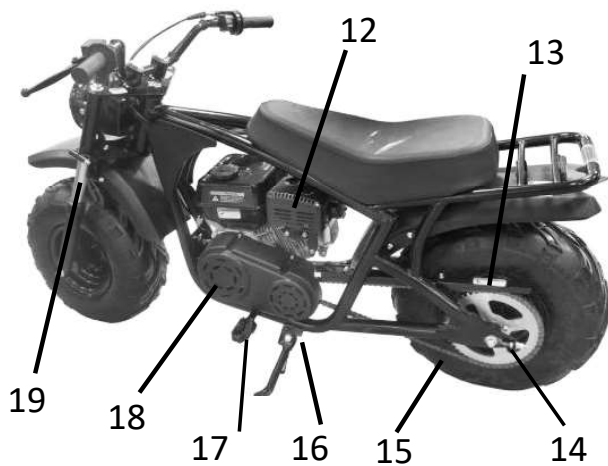

20. Rear Brake Lever
21. Headlight
22. Throttle Cable
23. Left Hand Brake Grip
24. Headlight switch
25. Engine Stop Switch
26. Throttle Grip

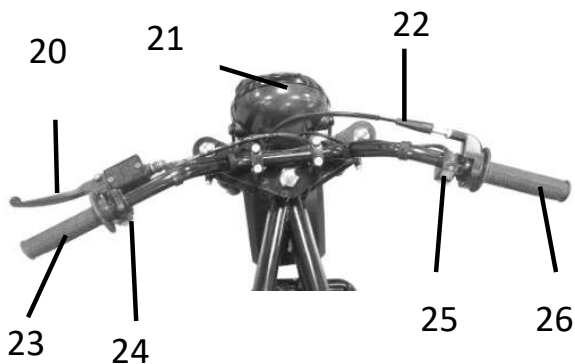

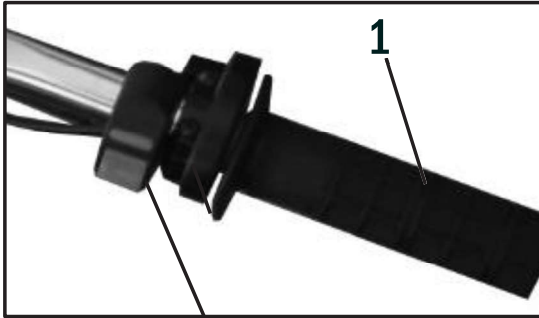

DESCRIPTION AND PART FUNCTIONS

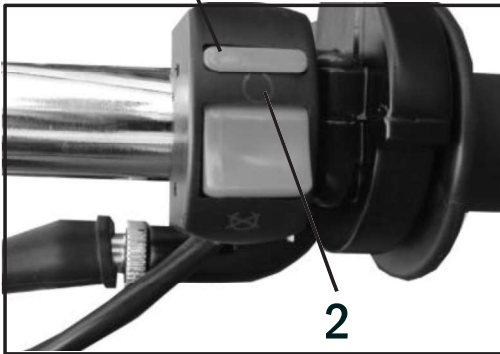

Throttle Grip(1): The engine speed is regulated by the position of the right throttle grip. Throttle is increased by turning the throttle grip toward the operator. Engine speed is decreased by turning the throttle grip away from the operator.



Engine Stop Switch (2): Mini Bike engine can start when the Engine stop switch is placed in the  (on) position. Engine will shut off and the engine will not start when the switch is placed in the  (off) position.

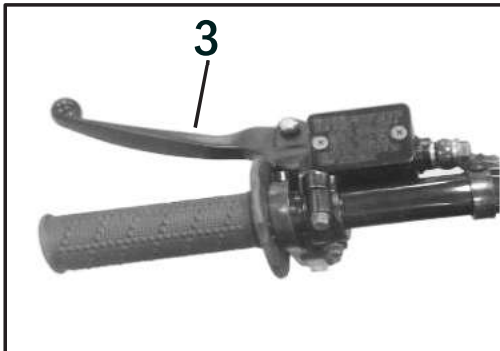

Left hand brake lever (3): The rear brake is applied when the left hand brake lever is pulled toward the hand grip.

DESCRIPTION AND PART FUNCTIONS



Choke operation

Choke Lever (1): If the engine is cold, the choke can help start the engine by placing the choke lever to the “ON” (left) position. Once engine has warmed up, place choke lever to the “OFF” (right) position.

Fuel Valve operation

Fuel Valve (2): To start the engine and run the mini bike, the fuel valve needs to be placed in the “ON” (right) position. This allows fuel to flow to the carburetor. When finished riding, and while transporting, place fuel valve in the “OFF” (left) position.

1 2
4 3



Fuel Cap

Fuel Tank Cap

To open the fuel tank cap (3), Turn the cap counter clockwise to remove. To re-install the cap, turn the cap clockwise until snug.

Starter Recoil Cord

Starter Recoil Cord (4)

To start the engine, place the on/off switch locate on the handlebars to the “ON” position and pull the Starter Recoil Cord

5

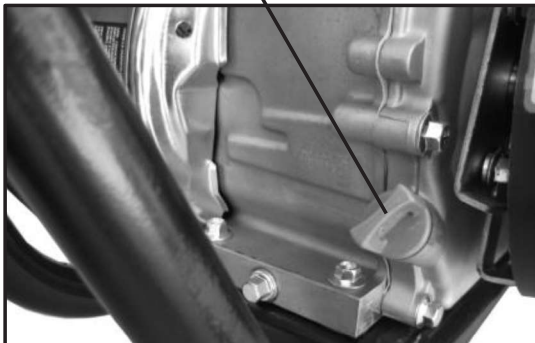

Oil Fill plug

Oil Fill Plug (5)

To check or add oil, open the oil fill plug/ dipstick by turning counter clockwise. To tighten, turn clockwise.

FUEL

Never use leaded gasoline in this product. It could affect the engine's emissions and damage the engine. Mini Bike requires clean unleaded regular gasoline with a minimum octane rating of 86 or higher.

Gasoline/ Ethanol blends

A blend of unleaded gasoline with Ethanol, also known as GASOHOL, at or below 10% (E10) can be used in your Mini Bike. Ethanol greater than 10% can damage your engine and will void your warranty.

Gasoline/Methanol Blends

A blend of gasoline with Methanol of 5% or less can be used in your Mini Bike. Do not use gasoline, under any circumstances, containing more than 5% Methanol, doing so will damage your engine and will void the warranty.

Fuel Filling

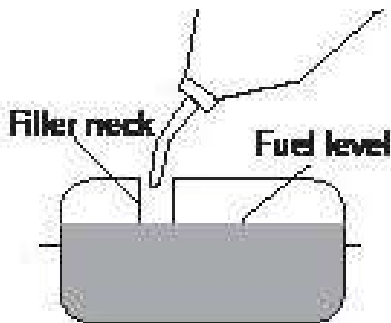

⚠ WARNING

Over filling the fuel tank can cause the fuel to expand which can cause overflow due to the heat from the engine or sun. Spilled fuel can catch fire.

Never fill the fuel tank above the bottom of the filler neck.

FUEL AND OIL

⚠ WARNING

Fuel and fuel vapor are highly flammable and toxic. You can be burned or poisoned while refueling.

Before refueling make sure to follow the procedures listed:

- 1 Shut off engine, Make sure there are no flames, sparks or heat sources close by.
- 2 Refuel only outdoors in a well ventilated area.
- 3 Do not smoke while refueling.
- 4 Wipe up any spills immediately.
- 5 Avoid breathing any fuel vapors.
- 6 Keep children and pets away.

ENGINE OIL

The recommended oil for this Mini Bike is SAE10W-30 motor oil, if this oil is not available, any of the oils on the chart below will work. Note the temperature requirements for each of the oils.

Quantity of oil - .45L

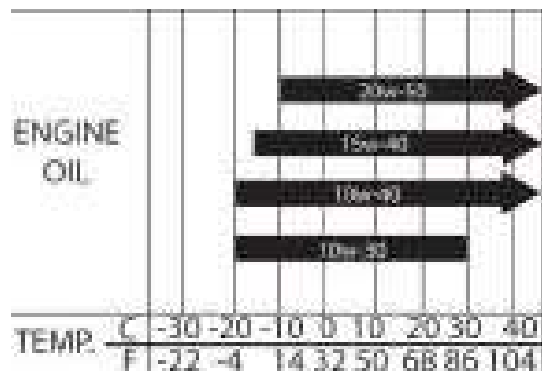

PRE-RIDE INSPECTION

Inspecting and checking the condition of the Mini Bike before each ride is important. Following the pre-ride check list will help insure the you do not have mechanical problems which could result in injury or becoming stranded. Make sure the Mini Bike is in good operating condition before each ride.

⚠ WARNING

Failing to inspect and maintain your Mini Bike could be hazardous.

Not following the pre-ride inspection procedures could result in loosing control of the Mini Bike resulting in an accident or damage to the Mini Bike

Always perform a pre-ride inspection before each ride.

⚠ WARNING

Performing maintenance and checks while the engine is running could be hazardous.

You could be severely injured by moving parts or hot surfaces.

Never perform maintenance or check procedures while the engine is running with the exception of checking the engine stop switch or throttle.

WHAT TO CHECK	CHECK FOR
Steering	<ul style="list-style-type: none"> • Smoothness • No restriction of movement
Brakes	<ul style="list-style-type: none"> • Brake pad wear. • Proper brake lever play
Tires	<ul style="list-style-type: none"> • Proper tire pressure • Proper tread depth • Rubber has no cracks
Fuel Tank	<ul style="list-style-type: none"> • Enough fuel for the ride • Fuel cap secure • Hoses have no signs of cracks or leaks
Throttle grip	<ul style="list-style-type: none"> • Throttle grip snaps back to idle when released • Operates freely • Has correct free play
Engine Stop Switch	<ul style="list-style-type: none"> • Switch shuts off engine when activated.
Engine Oil	<ul style="list-style-type: none"> • Correct oil level
Drive Chain	<ul style="list-style-type: none"> • Proper tension • Lubricated • No excessive wear or damage
General Condition	<ul style="list-style-type: none"> • All nuts and bolts tight • No rattles from engine or frame while running

RIDING THE MINI BIKE

HELMET, EYE PROTECTION, PROTECTIVE CLOTHING

Always wear a DOT or SNELL certified motorcycle helmet (1). A helmet helps protect against serious head injuries in the event of an accident. A helmet is the most important safety gear item you can wear. Consult with a motorcycle dealer for the correct size and type of motorcycle helmet that is right for you.

Always wear eye protection when riding a Mini Bike such as a face shield or goggles (2). While riding a Mini Bike you can be hit in the eyes by any of the following: dust, branches, rocks, debris from other riders, bugs, etc. Good eye protection as well as a helmet and protective riding gear should be mandatory when riding a Mini Bike.

Wear protective clothing: Long sleeve shirt (3), Gloves (4), Long pants (5), over the ankle boots (6).

Riding a Mini Bike exposes the rider to many hazards, wearing protective clothing can help protect the rider from injury.

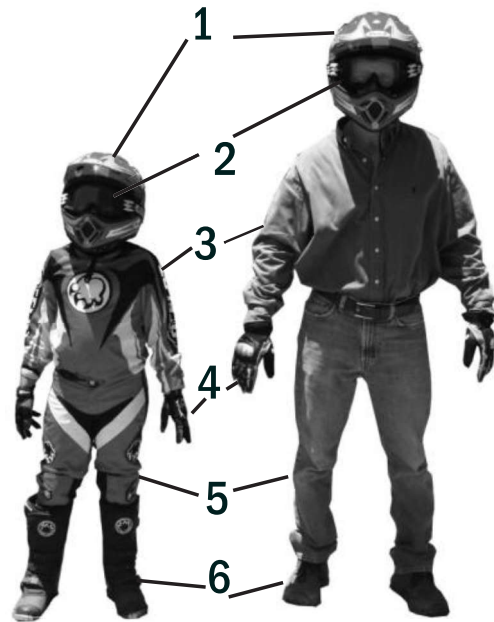

⚠️ WARNING

Riding the Mini Bike without a helmet, eye protection, and protective clothing can be hazardous

Riding a Mini Bike without a helmet increases the chance of severe head injury or death in the event of an accident.

Riding a Mini Bike without eye protection such as a face shield or goggles could result in severe injury in the event of an accident.

Riding a Mini Bike without protective clothing; over the ankle boots, long pants, gloves, long sleeve shirt could result in severe injury in the event of an accident.

Always wear a Helmet, eye protection, long pants, long sleeve shirt, over the ankle boots and gloves when riding the Mini Bike.

RIDING THE MINI BIKE

STARTING ENGINE

To start the engine

1. Place the fuel valve (1) in the “ON” (right) position.
2. If engine is cold, place the choke lever (2) in the “ON” (left) position.
3. Place the ON/OFF switch (3), located on the handlebars, in the  (on) position.
4. Pull the starter recoil cord (4) to start the engine.
5. Once engine has warmed up for a few minutes, place the choke lever (2) back to the “OFF” (right) position.

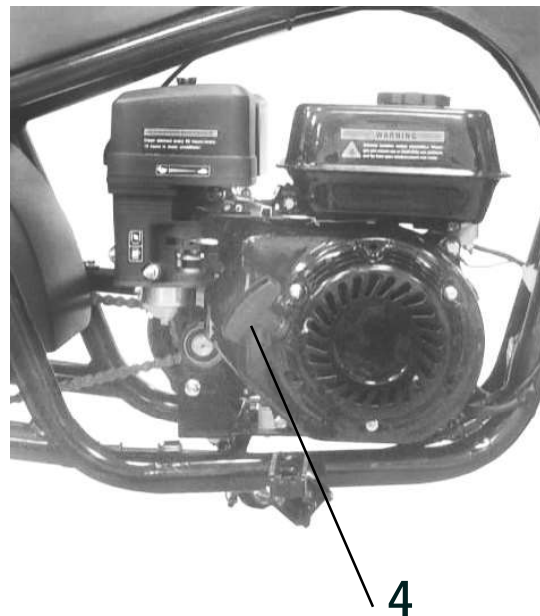
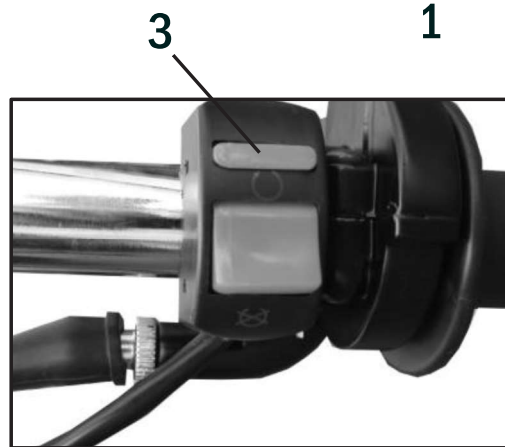
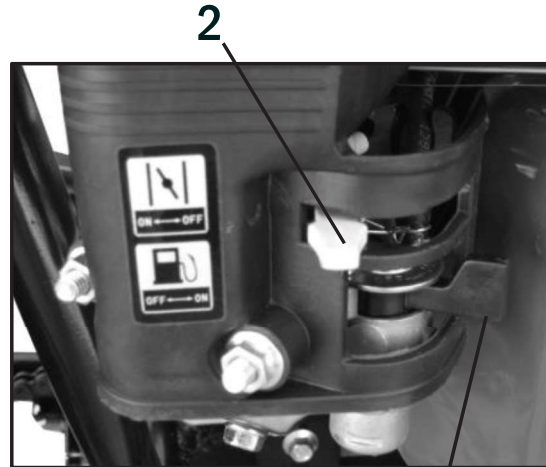

WARNING

Starting or running the Mini Bike in an enclosed area such as a garage or shed where there is no ventilation is hazardous

Inhaling exhaust fumes from the Mini Bike can cause severe injury or death

Never start or run the Mini Bike in an inclosed environment where there is no ventilation. Always start and run outdoors.

RIDING THE MINI BIKE

STARTING OFF

1. Start and warm up the engine according to the instructions in this manual.
2. Place the side kick stand in the up position.
3. Apply the throttle gradually to start riding. Practice riding Mini Bike on a flat dirt surface that has plenty of room for turning.

WARNING

Turning the throttle grip to full throttle when starting off could be hazardous.

The Mini Bike could lurch forward causing the front wheels to leave the ground causing loss of control.

Always open the throttle gradually when starting off from a stopped position.

WARNING

Operating this Mini Bike at excessive speeds could be hazardous.

Riding at excessive speeds increases your chances of losing control of the Mini Bike, which could result in severe injury or death.

Always go at a speed that is proper for the terrain, visibility, operating conditions, operator skill, and operator experience. Always know the terrain before riding.

WARNING

Removing hands from the handlebars and/or feet from the footrest while operating the Mini Bike could be hazardous.

Removing both or one hand from the handlebars and/or feet from the footrests could result in loss of control of the Mini Bike resulting in severe injury or death.

Always ride with both hands on the handle bars and both feet on the footrests while operating the Mini Bike.

WARNING

Braking while turning could be hazardous.

Braking while turning could cause the Mini Bike to slide out of control which could result in severe injury or death.

Before making a turn, slow down and release the brake.

RIDING THE MINI BIKE

Load Guidelines

Load guidelines including accessories:

Never exceed the maximum load capability of the Mini Bike. This includes the weight of the rider and any cargo. This Mini Bike is rated at 200 lbs. (91kg)

Do not add any accessory or cargo to the handlebars that could impede vision or make the Mini Bike harder to steer.

Make sure accessories do not get in the way of any controls of the Mini Bike.

After Market parts

After market parts and accessories may be available from other manufactures. DRIFT HERO USA can not confirm the quality, safety or suitability of accessories available. When purchasing an accessory, use caution, the handling of the Mini Bike could become affected. Some accessories may make the Mini Bike unsafe to ride. If you have a question about a modification or accessory, contact your dealer.

WARNING

Riding this Mini Bike with modifications or adding accessories could be hazardous.

Modifications to the Mini Bike, including adding accessories, could adversely affect the handling of the Mini Bike causing an accident which could result in severe injury or death.

Never Modify this Mini Bike in anyway, including adding accessories, unless the modification is a genuine certified modification or accessory approved by the manufacture. Never modify the Mini Bike with improper installation. Make sure to follow all instructions recommended in the certified modification. Use only genuine parts. For questions, contact your dealer.

MAINTENANCE

For maintenance, your mini bike may be maintained by an authorized DRIFT HERO service dealer or a repair shop of your choosing.

Following the proper maintenance procedures and time table for maintenance listed in this manual is important for the safety of the rider and the life span of the Mini Bike. When riding in harsh conditions, such as water, mud and dust, the maintenance procedures should be performed more often.

WARNING

Failing to perform the recommended maintenance on this Mini Bike could be hazardous.

Failing to perform proper maintenance on this Mini Bike could result in an accident

Always perform the recommended maintenance for the Mini Bike as noted in this manual.

WARNING

Performing maintenance and inspection while the engine is running could be hazardous.

Performing maintenance and inspections while the engine is running could result in getting body parts or clothing caught in moving parts, or could result in touching hot items which could result in severe injury.

Shut off engine when performing maintenance and inspection checks, with the exception of checking the engine stop switch and throttle.

CAUTION

Failing to perform recommended maintenance on this Mini Bike could damage the Mini Bike engine and components

Always perform the recommended maintenance on this Mini Bike as listed in this manual.

Maintenance will need to be performed more often if ridden in wet, muddy or dusty conditions.

CAUTION

Failing to use compatible parts with the original replacement parts could damage Mini Bike

Using parts that are of low quality could result in Mini Bike break-downs and reduce the useful life of the Mini Bike.

Never use parts that are not compatible with the original parts..

MAINTENANCE CHART

ITEM	First 5 of operation	Before Each Ride	Every 20 hours of operation or 1 Month	Every 50 hours of operation or 3 Months	Every 100 hours of operation or 6 Months
Exhaust pipe nuts & muffler bolts	T	I	T		
Air cleaner element	I		I		
Valve Clearance**					I
Spark Plug			I		R
Fuel Line		I			
Idle speed	I		I		
Condition of throttle and brake cables	I	I			
Engine oil	R	I		R	
Drive Chain	Inspect drive chain before each ride. Clean and lubricate as necessary				
Brakes	I		I		
Brake hose	I		I		
Brake fluid	Inspect brake fluid level before each ride, if low, check brake pads for wear and brake lines and components for leaks. Replace brake fluid every 2 years.				
Tires		I			
Steering	I		I		
Front suspension	I		I		
Rear suspension	I		I		
Chassis nuts and bolts	T	I	T		

****Recommended to be performed by an authorized service center or service center of the owner's choosing.**

NOTE:

I = INSPECT AND CLEAN, ADJUST, REPLACE OR LUBRICATE AS NECESSARY.

R = REPLACE

T = TIGHTEN

MAINTENANCE

Air Filter

The air cleaner element needs to be cleaned or replaced periodically (see chart for cleaning/replacement intervals). The air filter element will need to be cleaned more often if Mini Bike is ridden in muddy, wet, or dusty conditions. A clean air filter will help the Mini Bike run at peak performance allowing better gas mileage, more power and will protect the engine from the damaging effects of dirt entering the engine.

Air filter removal, inspection and cleaning instructions

1. Locate the air filter assembly (1)
2. Remove the Air filter assembly cover by removing the air filter cover knob (2).
3. Remove the air filter element from the assembly by removing the wing nut (3)
4. Remove the foam element (4) from the paper air filter element (5) and clean foam element with mild soap and water. Rinse and squeeze out excess water and allow to dry .

Note: If foam element (4) is damaged, replace.

5. Inspect the air filter paper element (5) for dirt and damage. If dirty, gently tap element on ground to remove any excess debris. Gently blow out element from the inside with compressed air. If element is too clogged or damaged for continued use, replace the element.
6. Once cleaned or replaced, re-install.

CAUTION

Clean air filter frequently if Mini Bike is driven in wet, muddy or dusty conditions.

Driving in the above conditions without cleaning frequently can plug up the air filter which can cause poor gas mileage, low power and cause damage to the engine.

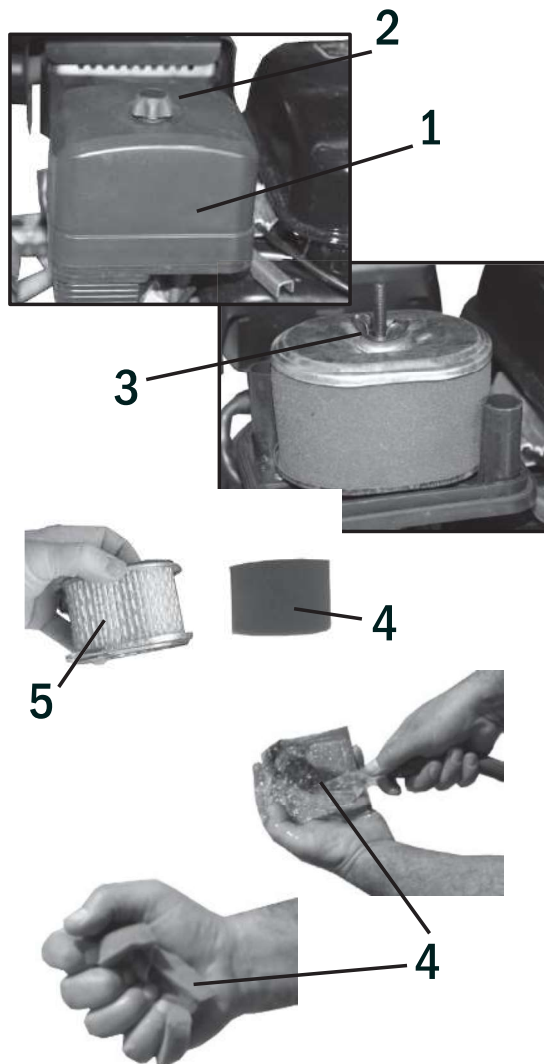

MAINTENANCE

Spark Plug

This Mini Bike comes equipped with a F6TC spark plug.

To inspect the spark plug, remove the air filter cover and element to gain access. Remove spark plug cap (1) then remove the spark plug from the engine with the spark plug tool provided.

Inspect the plug for carbon deposits and clean if necessary. If plug shows excessive carbon, replace the plug.

CAUTION

Dirt can damage the engine if it enters the spark plug hole.

Make sure the spark plug hole is covered after removing plug.

Use a thickness feeler to inspect the spark plug gap (2). The spark plug gap should be 0.6 - 0.8mm (0.024 - 0.032 in.)

Re-install the inspected plug or new plug until finger tight. Finish tightening plug with a wrench. If the plug is a new plug, tighten approximately 1/2 turn more with the wrench. If plug is an old plug, tighten approximately 1/8 turn more with a wrench.

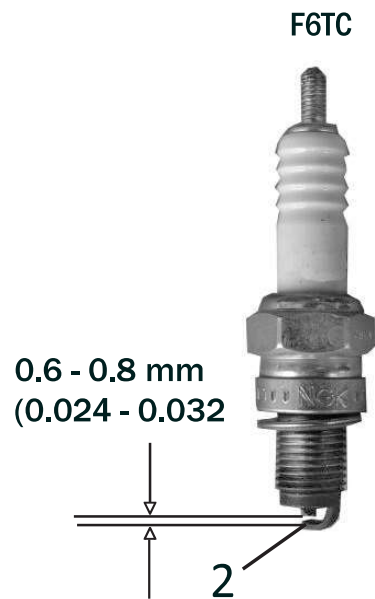
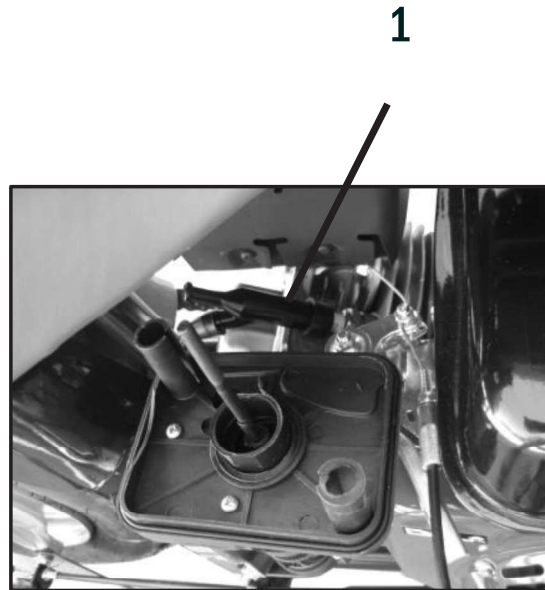

MAINTENANCE

Engine Oil

The proper amount and grade of engine oil will have a great impact on the life of the engine. Checking the oil daily and changing the oil as listed in the maintenance schedule is the most important maintenance procedure for the engine.

Checking the engine oil

1. Make sure the Mini Bike is on level ground.
2. Check engine oil level by removing the oil fill plug/dipstick (1) located on bottom front left front side of the engine.
3. If engine oil is low, add oil until oil is at edge of fill hole (2). Use the correct grade of oil as listed in this manual. Do not over or under fill engine with oil, this could damage the engine.

Changing the engine oil

1. Make sure engine is warm before attempting to drain the oil. A warm engine will help the oil drain quicker.
2. Remove the oil fill plug (1)
3. Remove the drain bolt (3) located on the bottom of the engine.
4. Allow the oil to drain in an appropriate container. Note: Dispose of oil at an oil recycle center.
5. Install the drain plug and fill with the appropriate type of oil as listed in this manual. This mini bike takes .63qt. (.6L) of engine oil.
6. Re- install fill cap, Start engine and allow to run for a few minutes, Re-check oil level and fill accordingly.

⚠ WARNING

New and used oil can be hazardous

Children and pets can be harmed by swallowing new or used oil. Continuous contact with used engine oil has been found to cause skin cancer in laboratory animals

Always keep new or used oil away from children and pets.

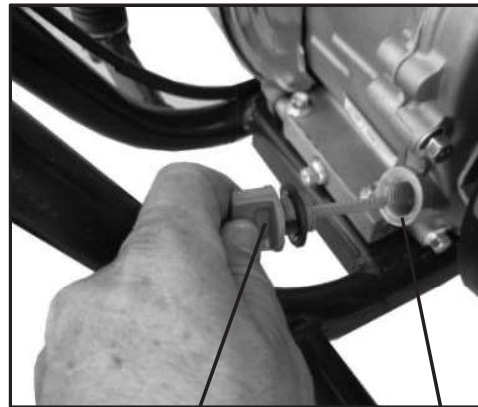

1 2

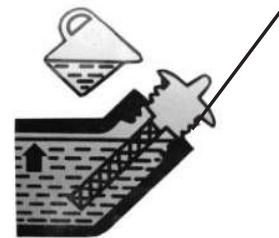

1



3

MAINTENANCE

Throttle Cable adjustment

It is important that the throttle grip have a certain amount of free play so the throttle does not rise when the handlebars are turned from left to right.

The hand grip throttle free play (2) should be .078 - .24 in (2-6 mm)

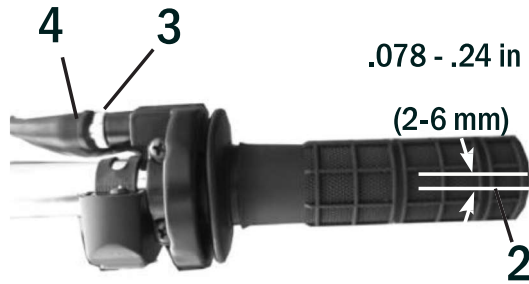

To adjust free play

1. Loosen jam nut (3)
2. Turn adjusting nut (4) to proper setting
3. Once throttle grip is at the proper free play, re-tighten the jam nut (3).

NOTE: After any adjustment, make sure throttle snaps back to idle when released.

Fuel Hose Inspection

Inspect the fuel hose for any cracks or leaks and make sure all clamps are in place. Replace the fuel hose if any defects are found.

Valve Clearance:

Adjusting the valves should be done by an authorized service center. Proper valve gap will help Mini Bike run at peak performance. Follow the valve gap adjustment intervals listed in the maintenance chart.

WARNING

Inadequate throttle play can be hazardous

The engine speed could rise when the handlebars are turned if there is not enough throttle play. This could result in loss of control.

Always check throttle play before each ride. Turn handlebars from side to side making sure throttle does not increase when doing so.

Proper Valve Clearance

Intake: 0.1 - 0.15 mm

Exhaust: 0.1 - 0.15 mm

MAINTENANCE

BRAKES

This Mini Bike is equipped with rear hydraulic disk

! WARNING

Failing to inspect brakes before each use could be hazardous
Inspect brakes before each use according to the pre-ride check list, make sure to follow the maintenance schedule and procedures.

BRAKE FLUID INSPECTION

Check the brake fluid level (1) for rear brakes. If fluid level is below the lower mark, inspect the brake hoses (2) for leaks or cracks. If there are no leaks, inspect the brake pads for excessive wear. If brake pads are worn, take to a service center for replacement. To add brake fluid, remove the lid (3). Use only DOT3 or DOT4 brake fluid

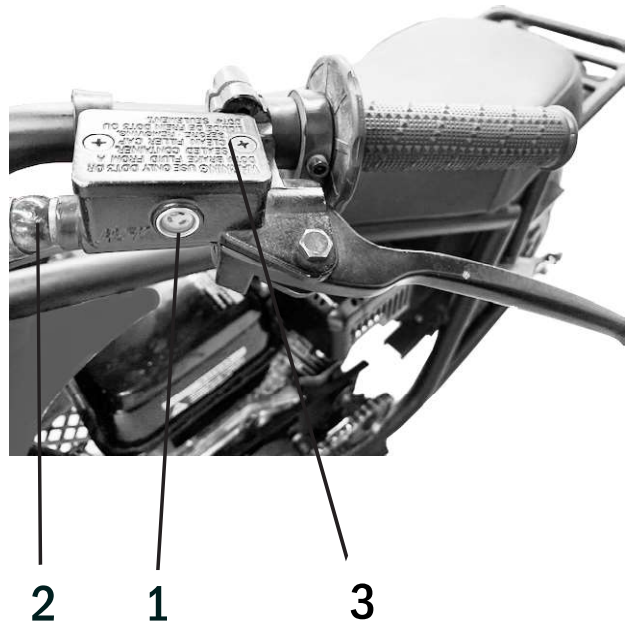

MAINTENANCE

Chain

Chain and Sprocket Inspection

Inspect the drive chain for wear, rust, bound links, proper lubrication and proper tension.

If the drive chain has a problem correct or replace. Contact a service center for chain replacement.

A worn drive chain could also mean the sprockets may be worn.

Look for the following on the sprockets (1): Worn teeth, broken or damaged teeth, Loose sprocket mounting nuts.

If the sprocket shows signs of wear, contact a service center for replacement.

Chain tension

Check the tension of the chain. The chain (1) tension should be $1/2 - 3/4$ in. (15-20mm)

Chain tension (slack) adjustment

1. Loosen bolts under engine (2) on the rear axle assembly.

2. Adjust chain tension by turning the tension nuts (3) (Note: tension nuts are located on both sides of the mini bike.) Clockwise will tighten the chain. Counter clockwise will loosen the chain.

3. Once the chain is at the correct tension re-tighten axle bolt (2).

4. Re-check chain tension.

Chain lubrication

Lubricating the chain before each ride will help to ensure maximum life of the chain and sprockets.

Instructions for cleaning and chain lubrication:

1. Clean chain with a chain cleaner.
2. Lubricate chain with chain lube.

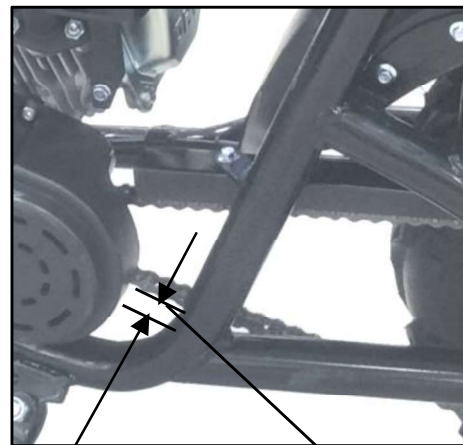
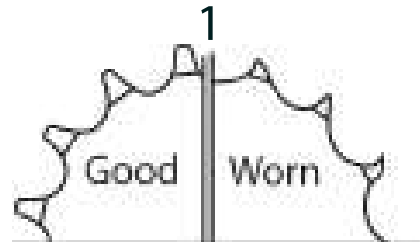

1/2 - 3/4 in.
(15-20mm)



2 3

MAINTENANCE

Centrifugal Clutch Cleaning and Lubrication

To help ensure the maximum life out of the Centrifugal clutch. It is important to clean and lubricate the clutch after every 5 hours of operation. To Clean and lubricate, follow the instructions below

1. Make sure engine is not running and that the engine and clutch has had time to cool.
2. Remove clutch cover (1).
3. Wipe off Centrifugal clutch (2) with a clean rag.
4. Lubricate Centrifugal clutch (2) using the same type of motor oil that is used in the engine. Place a few drops of motor oil on the drive shaft (3) where the clutch is attached. Do not oil any other portion of the clutch. **DO NOT PLACE ANY OIL IN THE LARGE HOLES IN THE CLUTCH. THE HOLES ARE FOR AIR CIRCULATION ONLY. DO NOT OIL THE INSIDE OF THE CLUTCH.**
5. **RE-INSTALL THE CLUTCH COVER BEFORE STARTING OR OPERATING THE MINI BIKE.**

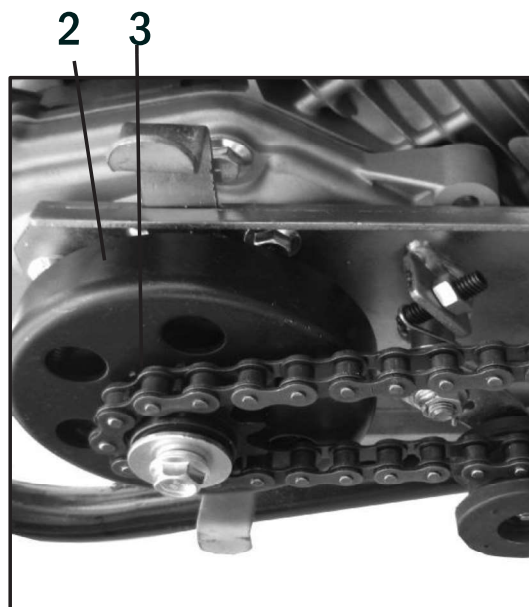
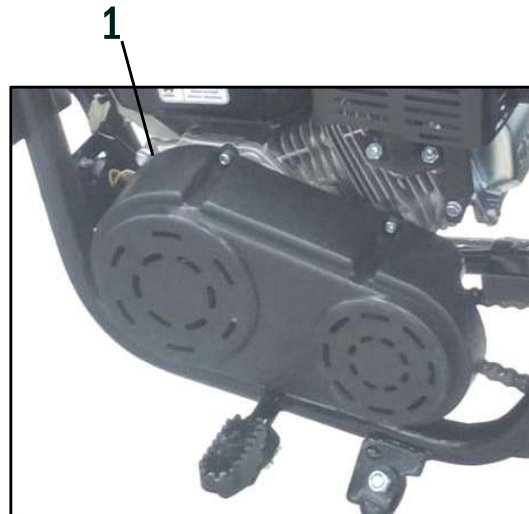

WARNING

Performing maintenance and inspection on the centrifugal clutch while the engine is running could be hazardous.

Performing maintenance and inspections on the centrifugal clutch while the engine is running could result in getting body parts or clothing caught in moving parts, or could result in touching hot items which could result in severe injury.

WARNING

Operating the mini bike without the clutch cover in place could be Hazardous.

Operating the mini bike without the clutch cover could result in getting body parts or loose clothing caught in moving parts which could result in severe injury.

Never Start or operate the mini bike without the clutch cover in place.

MAINTENANCE

Tires

Inspect tires before each ride, this should include the following:

1. Inspect for cracks or leaks
2. Inspect tread depth. If tread depth is below 4mm (.16 in.) replace the tire.
3. Check tire pressure. Incorrect tire pressure can affect the handling, rider comfort, steering, tire life and traction. Always check the tire pressure before each ride.

Tire pressure

Front tires: 10psi (69 kpa)
Rear tires: 10psi (69 kpa)

Tire size:

Front tires: AT19x7-8
Rear Tires: AT19x7-8

Replacing tires

Always replace tires with type and size listed in this manual.

Always use the correct tools when replacing tires. The bead and sometimes the rim can be damaged by using the wrong type of tools. It is usually best to have tires replaced by an authorized service center. Service centers have the correct equipment and expertise to change tires without causing damage.

Punctures to tires can usually be repaired by using plug type patches. Plug type patches cannot repair tires that have been cut. If the tire has been cut or has a puncture in a location or size that cannot be repaired, replace the tire.

Be prepared for flat tires, always carry a plug type patch kit and air pump with you.



Minimum tread
4mm (.16 in.)



⚠ WARNING

Operating this Mini Bike with worn tires could be hazardous. Operating this Mini Bike with worn tires will reduce traction which could result in an accident.

Never operate this Mini Bike with tires that have a tread depth of less than 4mm (0.16 in.)

⚠ WARNING

Operating this Mini Bike with improper tire sizes or pressure could be hazardous. Operating this Mini Bike with improper tire sizes or pressure could result in loss of control of the Mini Bike which could result in an accident.

Never operate this Mini Bike with improper tire sizes or pressure.

Storage

If the Mini Bike is left unused for an extended period of time proper storage maintenance is required.

1. Wash Mini Bike thoroughly, then wax painted parts with a non abrasive auto wax. Coat vinyl seat and rubber parts with a vinyl/ rubber protectant.

Note: Keep water away from air intake and muffler outlet while washing to avoid water from entering the engine and/or components.

2. Drain carburetor by placing fuel valve (1) to the off position and opening the drain screw (2). Allow all fuel to drain from the carburetor. Once fuel is drained, re-tighten drain screw (2).

Note: Make sure to drain fuel in a proper storage container.

3. Fill fuel tank to full with gasoline mixed with fuel stabilizer as recommended by the fuel stabilizer manufacture. Note: Fuel stabilizer can be purchased at most motorcycle shops and auto parts stores.

4. Remove spark plug and pour 1 tablespoon of motor oil in the spark plug hole. Re-install spark plug.

5. Place the starter button to the off position and pull the start recoil cord a few times. This is to coat the inside cylinder head with oil.

6. Fill tires with correct air pressure.

7. If possible, store Mini Bike in a shed or garage with a cover to protect from dust, dirt and humidity. If the Mini Bike must be stored outdoors, cover completely with a good waterproof cover.

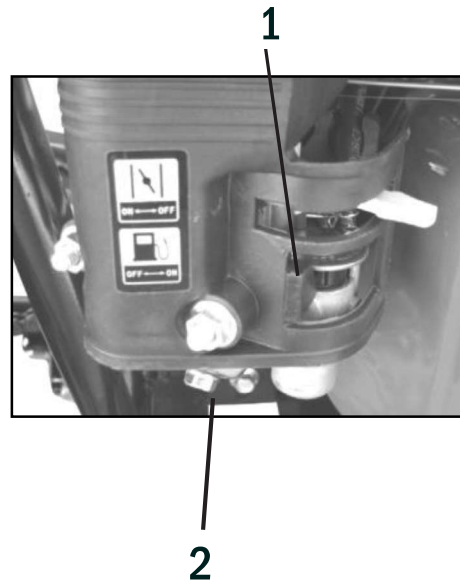

Returning to service

1. Wash Mini Bike thoroughly.

Note: Keep water away from air intake and muffler outlet while washing to avoid water from entering the engine and/or components.

2. Drain engine oil and replace with fresh clean oil as listed in this manual.

3. Review this owner's manual and follow the pre-ride inspection procedures.

4. Start engine by following the starting procedures in this manual.

Washing the Mini Bike

1. Wash mud and dirt off Mini Bike with low pressure water from a hose. Do not use high pressure nozzles, this could allow water to enter the engine causing damage.
2. Wash Mini Bike using a mild detergent or car soap using a sponge, soft rag or brush. Do not use any cleaning materials that could scratch the surfaces.

Note: Be careful not to allow water to enter the muffler outlet, air filter intake, brake cable, throttle cable or switches.

Transporting

1. Make sure fuel valve (1) is turned to the OFF (left) position.
2. Drain carburetor by turning fuel valve(1) to the off position and opening the drain screw (2). Allow all fuel to drain from the carburetor. Once fuel is drained, re-tighten drain screw (2).

Note: Make sure to drain fuel in a proper storage container.

3. Transport the Mini Bike with the Mini Bike in the upright position tied down securely.

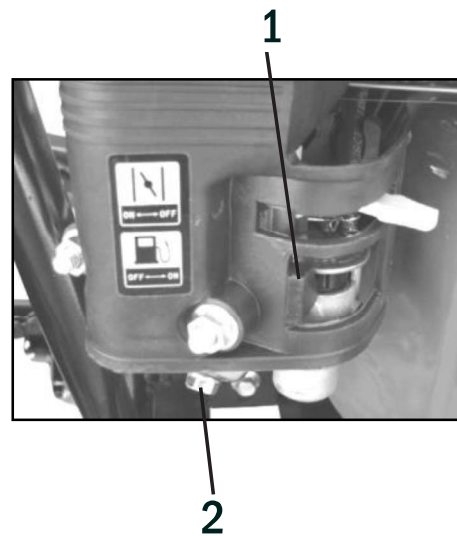

TROUBLESHOOTING

Trouble	Possible cause	Solution
<p>Engine will not start</p>	<ul style="list-style-type: none"> • Low fuel • Stale or contaminated fuel. • Fuel valve is in the “OFF” position • Loose spark plug • Spark plug fouled or defective. • Spark plug gap is incorrect • Spark plug cap is not attached • Choke is not in the “ON “ (left) position for starting a cold engine. • Problem with the electrical system • Air filter dirty • Valves not adjusted properly 	<ul style="list-style-type: none"> • Fill with fresh fuel • Have a service center flush and fill with fresh fuel. • Place fuel valve in the “ON” position. • Tighten spark plug • Clean or replace plug • Gap the plug • Attach spark plug cap • Place choke in the “ON” (left) position • Take to a service center for repair • Clean or replace air filter • Take to a service center for repair
<p>Engine stalls or runs erratically</p>	<ul style="list-style-type: none"> • Problem with the electrical system • Air filter dirty • Valves not adjusted properly 	<ul style="list-style-type: none"> • Take to a service center for repair • Clean or replace air filter • Take to a service center for repair

SPECIFICATIONS

<u>Engine</u>		<u>Tires</u>	
Displacement	212cc	Front Tire Size	AT19x7-8
Starting	Recoil Cord	Rear Tire Size	AT19x7-8
Spark Plug Type	F6TC	<u>Dimensions and Weights</u>	
Cooling	Fan cooled	Length	63.5in (1615mm)
Ignition Type	T.C.I	Height	36in. (915mm)
Cylinder head config.	OHV	Width	29.5in. (750mm)
Number of Cylinder	Single	Wheelbase	44.5in. (1130mm)
Combustion Cycle	4-stroke	Vehicle Wt.	158lbs (72kg)
Bore and Stroke	70mm x 55mm	Weight Cap.	200lbs (91kg)
Compression Ratio	8.5:1	Ground Clearance	5.9in (150mm)
Power	4.0kw @ 3600rpm	<u>Fuel</u>	
Rated Torque	12Nm @ 2500rpm	Gas Tank Capacity	.74gal. (2.8L)
Idle Speed	1600 ± 100 rpm	Fuel type	(4L) Unleaded 87 octane or higher
Top Speed	22mph (35km/h)	<u>Oil</u>	
<u>Transmission</u>		Oil Capacity	.45L
Drive System Type	Chain Drive	Oil Type	SAE 10W-30
Gear Ratio	7.5:1		
CVT Clutch			
<u>Suspension</u>			
Front Type	Front Fork Suspension		
Rear Type	Low pressure tires		
<u>Braking</u>			
Rear Brakes (Type)	Hydraulic disk		

FRAME AND ENGINE NUMBER LOCATION

The Vehicle identification number and the engine number are needed when calling for

parts, service center help or when registering your Mini Bike. Locate the numbers and list the numbers below for reference.

VIN#



The 17 digit Vehicle Identification Number (VIN) is located on the vertical tube on the neck of the mini bike

Vehicle Identification Number

--	--	--	--	--	--	--	--	--	--	--	--	--	--	--	--	--

ENGINE #

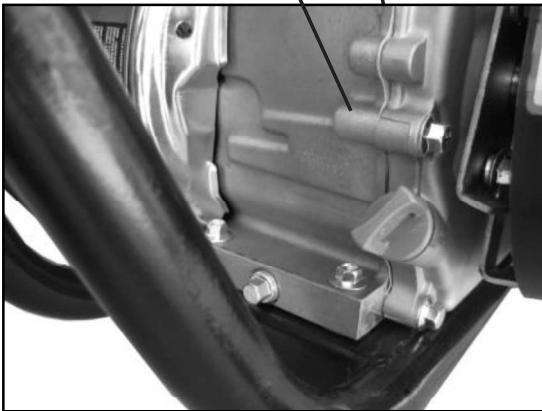

The engine number is located on the bottom front portion of the Mini Bike Engine.

Engine Number
