

FOR TURF NOT ASTRO.

1ST WATCH!



USA

VIDEO

You will build Open Goaaal significantly faster

USA - opengoaalusa.com/buildfullsize

UK - opengoaal.com/buildfullsize
(4 mins)



UK

REQUIRED



5.0m/16ft



Metal



QUESTIONS?

WARRANTY



Do not return product to store. First contact us

USA - wecare@opengoaalusa.com; www.opengoaalusa.com

UK - wecare@opengoaal.com; www.opengoaal.com

Other - www.opengoaal.com/contact

Register for warranty

www.opengoaal.com/apps/product-registration



WARNING

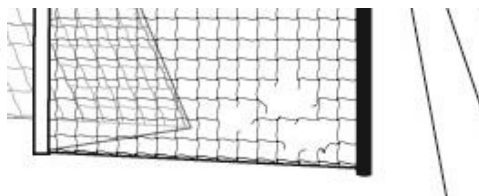
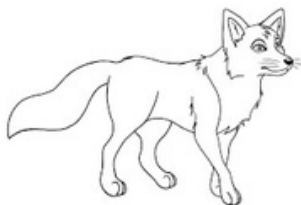



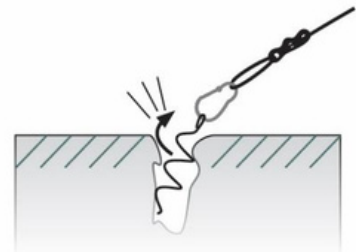















Avoid! Step 22





Check! Avoid! Step 23

KEEP THESE INSTRUCTIONS FOR PROBLEM SOLVING LATER.

PARTS

Part		Number	Part	Code
A		2	Pole Bottom	OGQ-POLE482-B
B1		2	Pole Lower Middle	OGQ-POLE482-LM
B2		2	Pole Upper Middle	OGQ-POLE482-UM
C		2	Pole Top	OGQ-POLE482-T
D		2	Pole Spike	OGQ-SPIKE-FS
E		10	Spiral Anchors	OGQ-SPIRAL-10MM-350
F1		4	Guy Rope (3.50m) & Lock & Large Carbine	OGQ-GUY4MM-3500 OGQ-GUYLOCK, OGQ-CARBL
F2		6	Guy Rope (5.50m) & Lock & Large Carbine	OGQ-GUY4MM-5500 OGQ-GUYLOCK, OGQ-CARBL
G		1	Topwire Bungee (6.75m)	OGQ-TOPW8MM-6750
H		5	Peg (4 + 1 spare)	OGQ-PEG
I		1	Net – Full Size	OGQ-NET-FS
J		2	Side Bungee (1.0m)	OGQ-SIDEB8MM-1000
K		18	Carbine Hook	OGQ-CARB
M		1	Crossbar Rope (4.7m) & Lock	OGQ-XBARR4MM-4700 OGQ-GUYLOCK
N		1	Crossbar Bungee (3.3m)	OGQ-XBARB10MM-3300
		1	Net Back Bungee (6.3m)	OGQ-NETBACK6MM-6300
O		2	Side Ropes (2.55m)	OGQ-SIDER-4MM-2550
P				
Q		1	Tightening Bar	OGQ-BAR

	<p>Do not return product to store. First contact us: USA - wecare@opengooaalusa.com; www.opengooaalusa.com UK - wecare@opengooaal.com; www.opengooaal.com Other - www.opengooaal.com/contact</p>	<p>Keep!</p> 
---	---	---

INTELLECTUAL PROPERTY – PATENTS

Open Goaaal is a registered trademark of Open Goaaal Investments Ltd. Patents and other intellectual property granted and pending, including China patent granted covering manufacture, import and export.
 Visit <http://opengooaal.com/pages/intellectual-property>.

WARNING

ASTM F2950-14 Warnings 1) Check for structural integrity and proper connecting hardware before every use. Replace damaged or missing parts or fasteners immediately. 2) Ensure safety/warning labels are clearly visible (placed under the crossbar and on the sides of the uprights at eye level). 3) Securely anchor movable soccer goals at ALL times, except when being moved. 4) Always instruct players, managers, coaches, trainers, teachers, maintenance and all other personnel who might come into contact with the goal on the safe handling of and potential dangers associated with movable soccer goals. 5) Always exercise extreme caution when moving goals and allow adequate manpower to move goals of varied sizes and weights. Movable soccer goals should only be moved by authorized and trained personnel. 6) NEVER allow anyone to climb on the net or goal framework. 7) Movable soccer goals should only be used on LEVEL fields, NEVER on a slope or hill area. 8) Remove nets when goals are not in use. 9) Most of the tip over injuries occurred when goals were unattended. Anchor or chain one goal to another, or to nearby fence posts, dugouts, or any other similar sturdy fixture when not in use. If this is not practical, store movable soccer goals in a place where children cannot have access to them. 11) Fully disassemble goals for seasonal storage.



WARNING: CHOKING HAZARD - Small parts. Not suitable for children under 3 years. Long cord. Strangulation hazard. Outdoor use only. Please retain this information. RECOMMENDED AGE 14+. WARNING: THIS TOY IS TO BE ASSEMBLED BY AN ADULT. In unassembled state it contains potentially hazardous sharp edges or points, so please keep out of children's reach. Open Goaaal Trading Ltd, PO Box 1185, WD23 9GJ. UK. www.opengooaal.com. Weight around 34kg.

SAFETY, MAINTENANCE & WARNINGS – for initial build, start of each season and regularly ongoing.



Please read carefully through the following information and keep these instructions in case you need to refer to them later. If you pass the product on to someone else, please also include these instructions.

THIS IS A TRAINING AID FOR SHOOTING PRACTICE, NOT A GOAL FOR GAME-PLAY, because the guy rope that extends onto the pitch at each end could be a trip hazard during game play.

DURING THE BUILD PROCESS MAKE SURE A SECOND ADULT HOLDS THE POLE WHEN INSTRUCTED TO DO SO. Otherwise there is a risk the poles will fall and cause damage or injury. The same applies if you take the goal down. Ensure you have someone hold the poles as you untie the ropes.

REGULARLY CHECK THAT THE ANCHORS REMAIN TIGHTLY EMBEDDED IN THE TURF. If you have softer turf and they are pulling upwards, then contact us. If these checks are not carried out the goal could collapse or otherwise become a hazard.

GENERAL INFORMATION

- Save all of the packaging materials until assembly is completed to avoid accidentally discarding any part.
- Carefully unpack all components and cross reference the parts list to ensure that all components are present. Always inspect the poles and net for defects before use and replace damaged parts.
- Keep babies and children away from the packaging material, all accessories and parts, due to suffocation and strangulation hazard.
- It is recommended not to use power tools during assembly to avoid damage and / or injury. Always instruct players, managers, coaches, trainers, teachers, maintenance workers and all other personnel who might come in contact with the product, on the safe handling of and potential dangers associated with the product.

INTENDED USE

- This product is designed for outdoor shooting practice only. Do not use for game play.
- Do not use this product for anything other than its intended purpose, and only use it as described in this manual. Any other use is not recommended and may cause injuries.

This product is not intended for use by persons (including children) with reduced physical, sensory or mental capabilities, or lack of experience and knowledge, unless they have been given supervision or instruction concerning use of the appliance by a person responsible for their safety.

- We accept no liability for any eventual damages caused by improper use or inappropriate handling, or by any other non-compliance with the instructions in this manual.

WHO SHOULD USE IT

- For soccer training and domestic outdoor use only.
- For ages 14+ years and upwards.
- Not suitable for children under 3 due to small parts and ropes which may represent an entanglement hazard.

GENERAL TRAINING SAFETY INSTRUCTIONS

- Do not use the product if you are suffering from any injury.
- Stop training and consult your doctor immediately if any health problems occur during training.
- Before you commence exercise, consult your doctor to determine that you are in a suitable state of health for training.
- Incorrect, inappropriate and overtraining can be damaging to your health.
- Loose-fitting clothing or jewellery can become an entrapment hazard. Wear appropriate and comfortable clothing.
- Appropriate workout shoes should be worn when using the product.
- Make sure you warm up before commencing exercise.

WHERE TO PUT IT

- **Only position the pole spikes and guy rope anchors in grass. Not in soil or other soft materials.**
- Not in front of house windows or valuable items. Although it is designed to provide a barrier for the ball, players may still “sky” the ball over the top of the net, or they may not close the curtain properly.
- Do not attach the guy ropes to fences. They are not designed to hold sideways forces and may tip over causing expense, serious injury or death. We strongly advise against this.

PUTTING IT UP

- Only to be built by 2 Adults.
- Do not climb a ladder without a second adult holding it firm.
- When hitting the pegs with the hammer, strike softly and frequently to protect your hands.
- **Very important. Ensure that the guy rope anchors and net pegs are inserted far enough into the ground so that the top is below the surface of the grass. Also, if the goal is taken down, the pole spikes must be removed from the ground as they present a protruding parts hazard which could lead to internal injuries and skin puncture if fallen upon.** Open Goaaal! does not accept liability for body, lawnmower or other damage caused by improperly inserted spikes, anchors and pegs.
- If you drill attachments into a wall to support the ropes or poles (which is not recommended), ensure that you wear goggles. Additionally, ensure that the wall is sturdy enough to take the tension.
- Any modifications to this product will void any and all warranties.

USING IT

- **Very important. Be aware of tripping over the guy ropes. Consider attaching a coloured flag to help them stand out.**
- Do not swing on the netting, cross ropes or guy ropes. Do not climb up the netting or poles. And do not run aggressively and crash into the poles or netting. These actions could cause the poles to fall over, so causing serious injury and/or expensive damage.
- Checked the stability of poles and anchors and for general safety before and after each use.
- All warning and safety labels included with this product must be visible at all times.
- Do not use the product if it is damaged or if parts are broken, missing and loose.
- Do not use the product during the threat of high winds.
- Clear any obstructions before using the product.
- Keep away from fire and heat sources.

MAINTAINING IT

- **Regularly check the guy rope anchors are tight in the ground below the surface of the lawn. If they are coming loose, then unfasten the ropes and tighten them into the ground. If they have come too loose, then you may need to move them by a small distance (see troubleshooting section).**
- Periodically check the poles for stability. If they are not, then tighten the guy ropes.
- Periodically check the netting and guy ropes for deterioration or damage; and repair any breaks in the net that could allow a ball to slip through.

We strongly recommend strimming the grass next to the poles, guy rope anchors and goal corner pegs, rather than lawn mowing. It's a lot easier than dis-assembling the goal. However, if you choose to mow over them ensure they remain inserted or tightened below the surface of the ground as per the build instructions so the lawnmower does not catch them. Also ensure you remove any carbine hooks that are hooked into them.

- Beware of catching loose ropes or net in your lawnmower. Be sure to lift them out of the way.
- When the product is not being used, raise the net off the ground as explained in the instructions.
- Foxes and other animals are known to chew and break garden netting. We advise that the goal is raised up each evening as a way of helping prevent this.
- **The product is under tension when set up. Please take the utmost care when releasing the tension during disassembly. Failure to do so may result in injury.** Remember to hold the poles during and after removing the bungees to ensure they don't fall risking injury or damage.

WARNING – AFTER EVERY USE, RAISE THE NET OFF THE GROUND HIGH ENOUGH TO PREVENT SMALL CHILDREN BEING ABLE TO BECOME ENTANGLED IN THE NET. ALSO TO PREVENT FOXES OR OTHER ANIMALS CHEWING THE NET. SEE STEP 22.

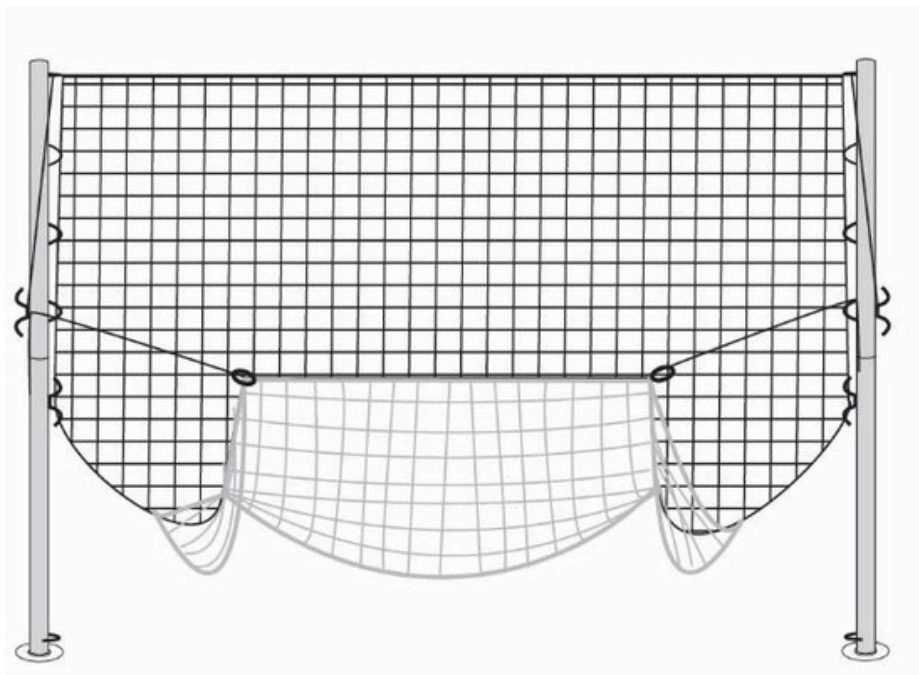

Locate area. Space behind goal is important. Anchor in grass, not soil or sand.

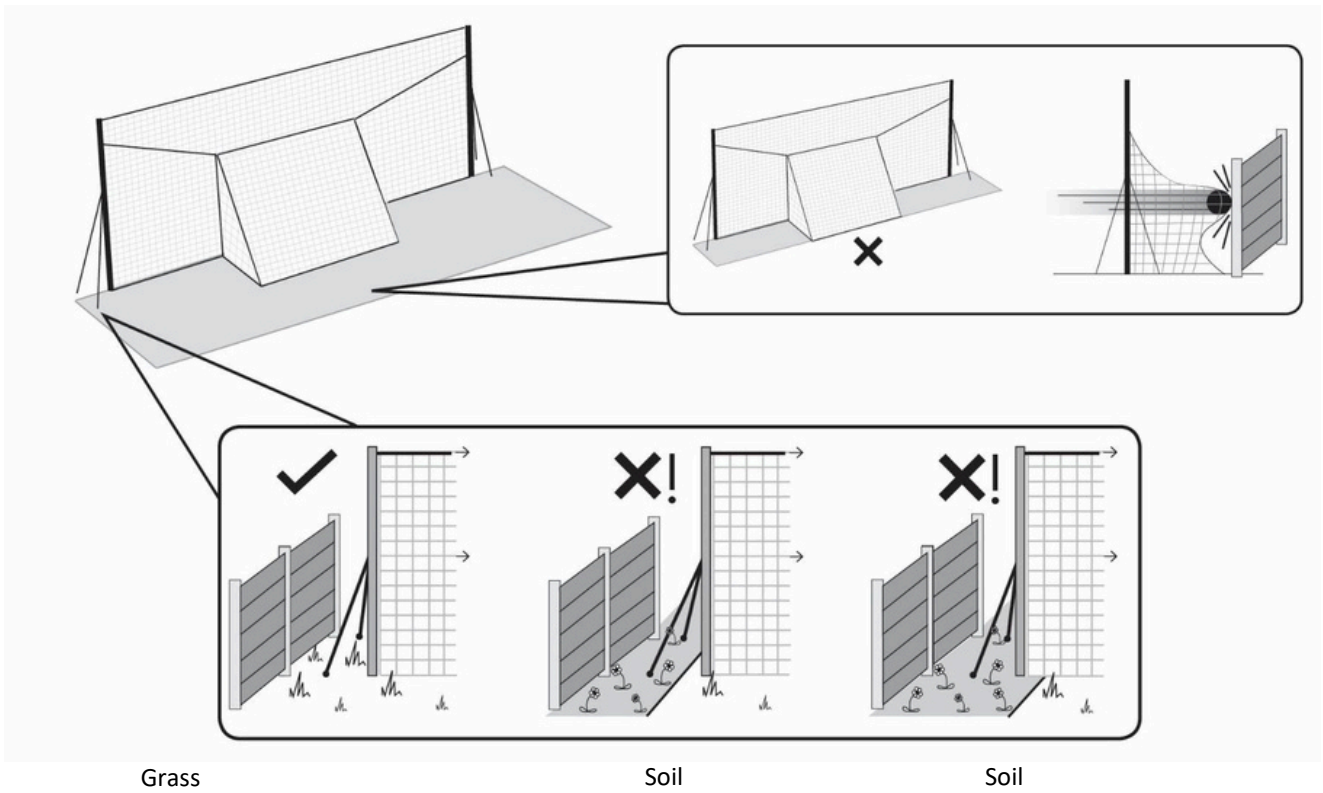

You will need an area of turf of these dimensions.

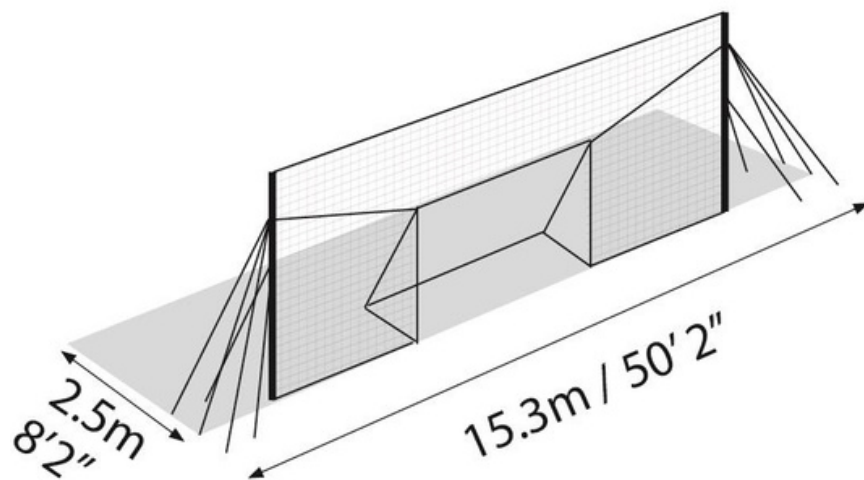

STEP 1 – Precisely measure and position the parts on the turf; BUT do not insert them yet.

Parts E x 10, D x 2, H x 2

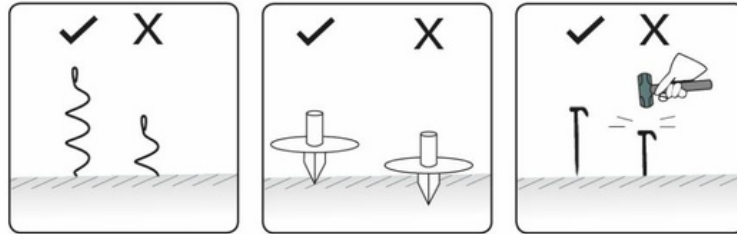

Do not insert yet

First...

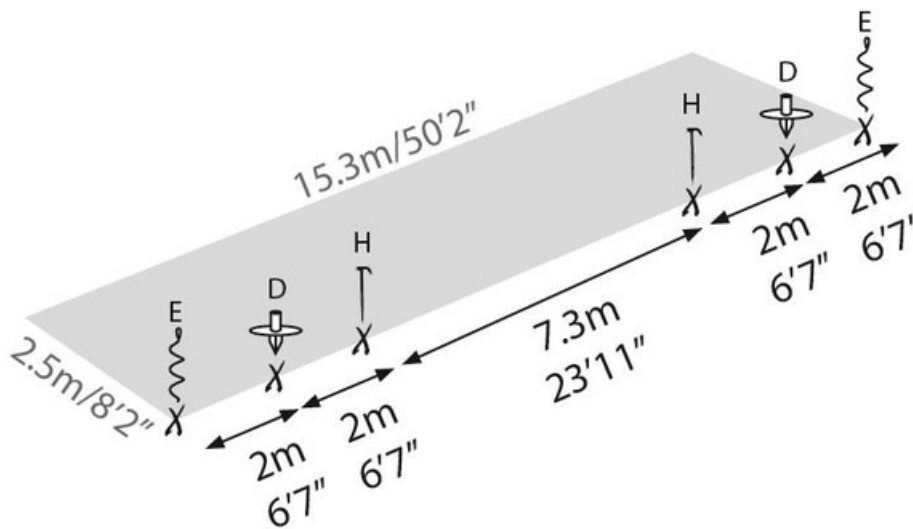

Then add the other 4 anchors at each end...

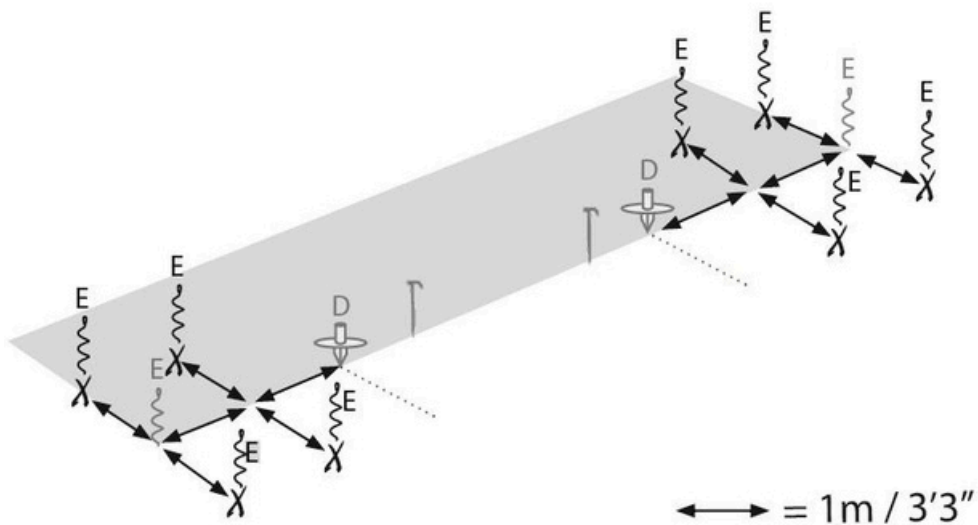

STEP 2 – Insert the Pole Spikes.

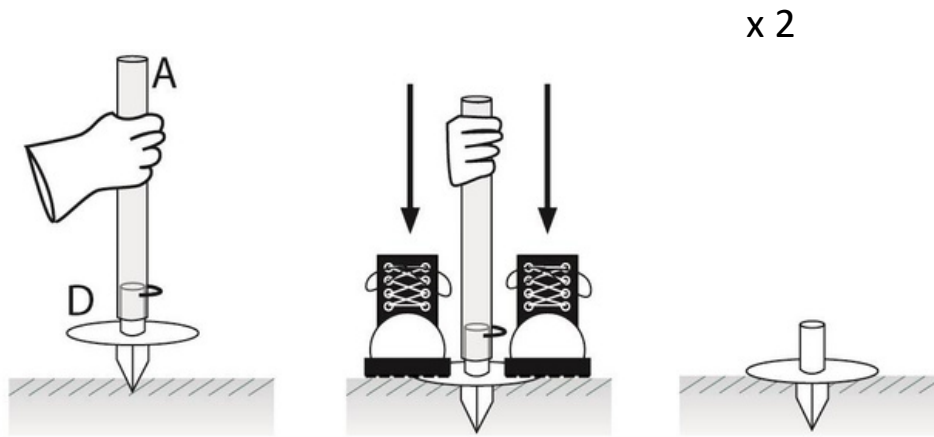

STEP 3 – Insert the Guy Rope Spiral Anchors using the Tightening Bar

Q x 1

x 10

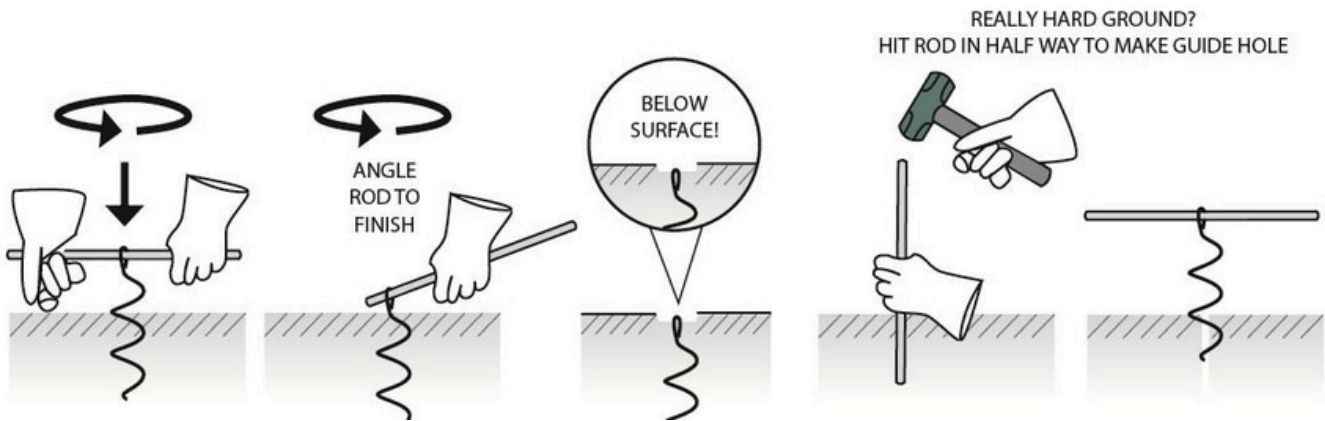

KEEP the Bar in a safe place for future tightening of Spirals!

STEP 4 – Insert the Pegs.

Part H x 1 (Temporary)

Dig hole with spare H

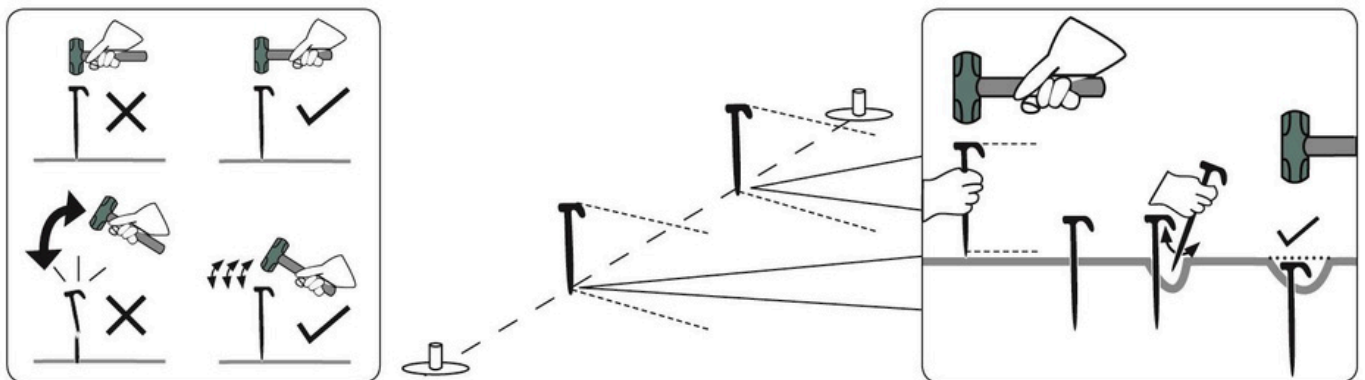

FRONT

Ground too hard? → **STEP 23**

STEP 5 – Attach the Guy Ropes to the Guy Rope Anchors, and leave them lying on the floor.

Part F1 x 4, F2 x 6

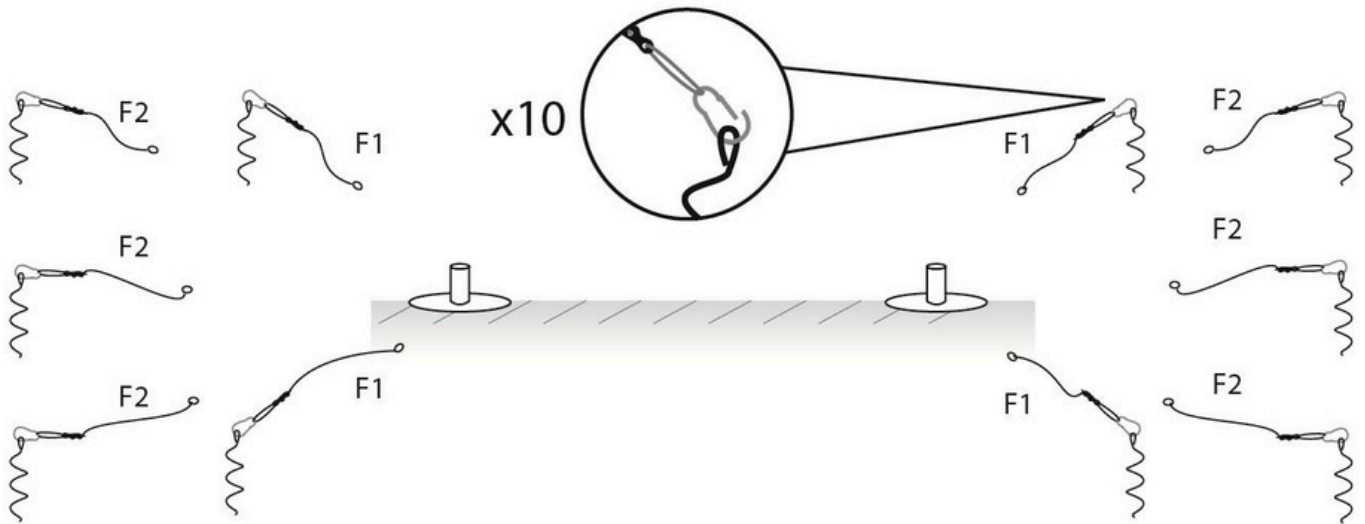

STEP 6 – Position the net on the floor

Part I x 1

LOGO THIS SIDE.

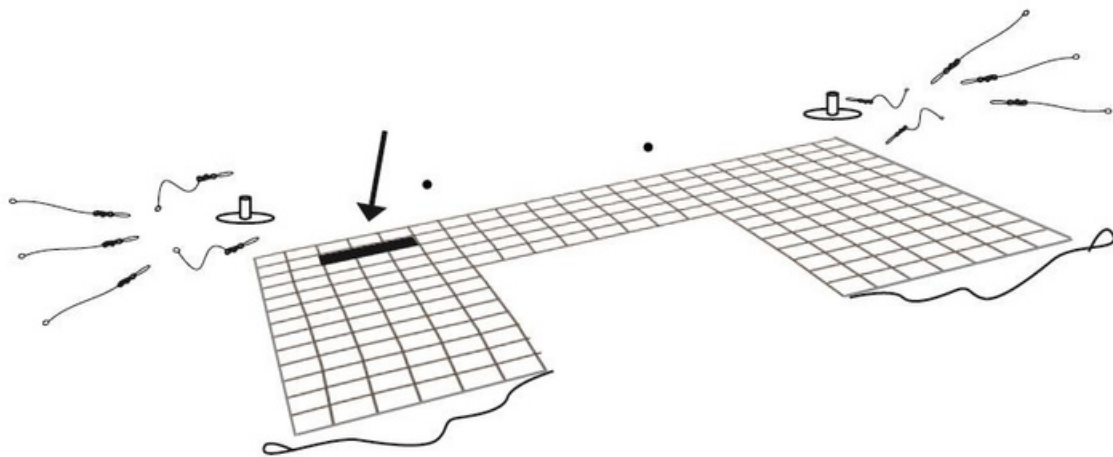

FRONT

STEP 7 – Attach the Side Bungees to the Bottom Poles

Parts A x 2, J x 2

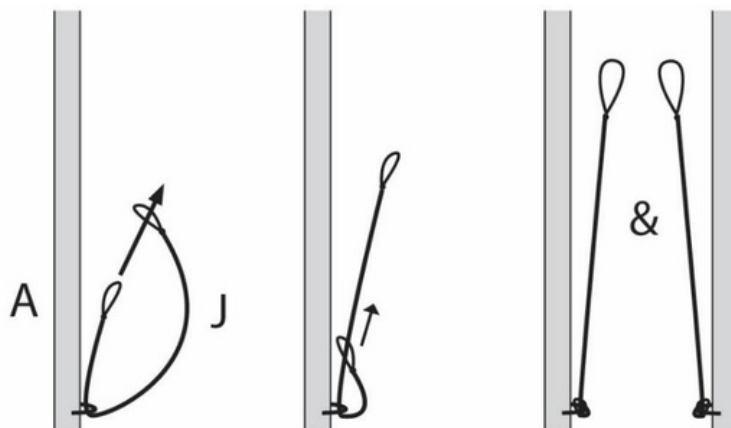

STEP 8 – Position the Poles. Ensure hooks and loops are pointing in right direction.

Parts A x 2, B1 x 2, B2 x 2, C x 2

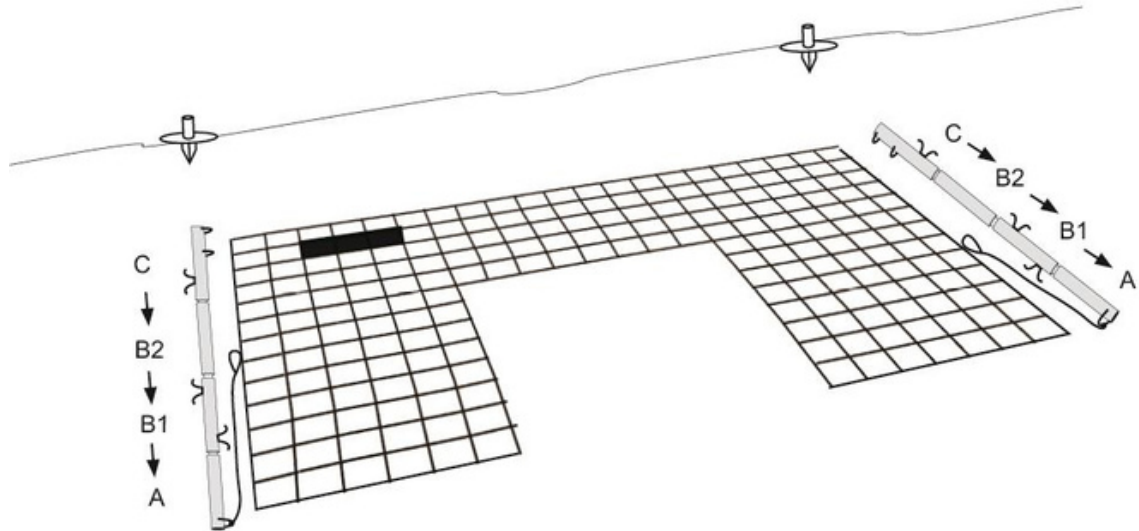

STEP 9 – 1. Weave the bottom bungees through the net to the outside on BOTH sides. Then 2. attach them to the bottom of the poles with a carabiner. 3 / 4. Hook the corner of the net into the carabiner.

Parts K x 2

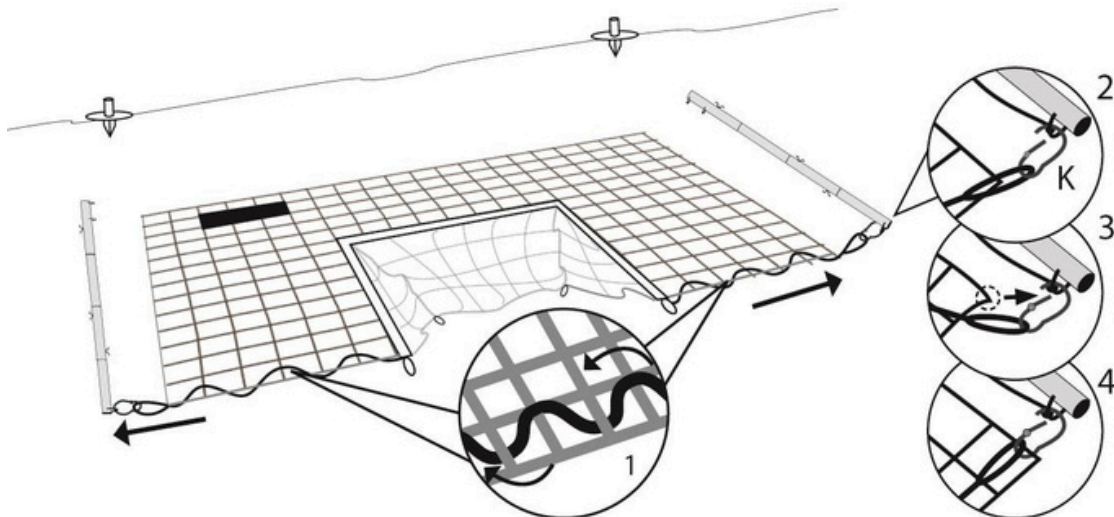

STEP 10 – Attach the Side Ropes to the Side Bungees on BOTH sides. Then attach the other ends to the top loop on top pole with a carabiner.

Parts P x 2, K x 2

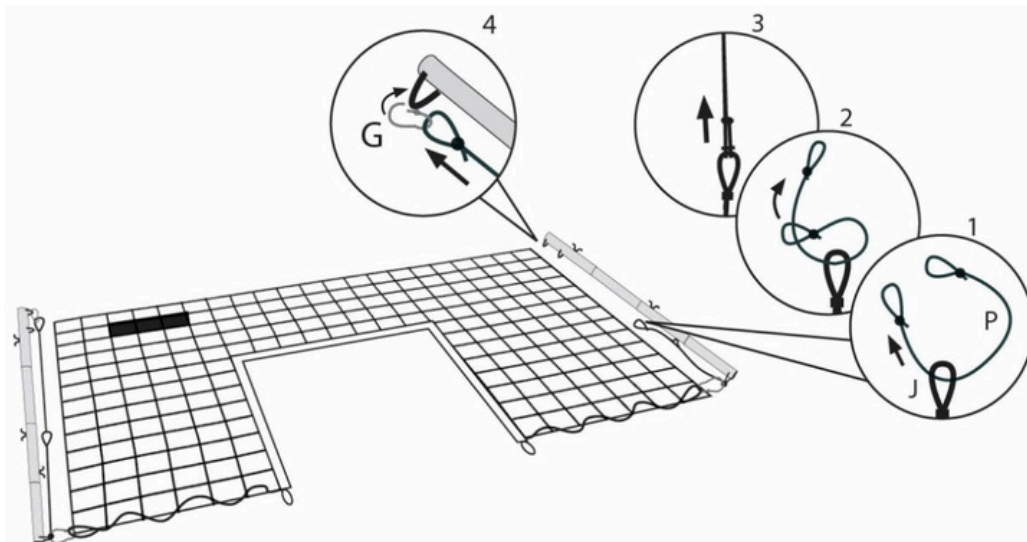

STEP 11 – Fold down the top right corner of the net, loop the Crossbar bungee through the pole loop, and fasten both ends of it to the carabiner at the top right of the goalmouth. Fold the net back.

Part N

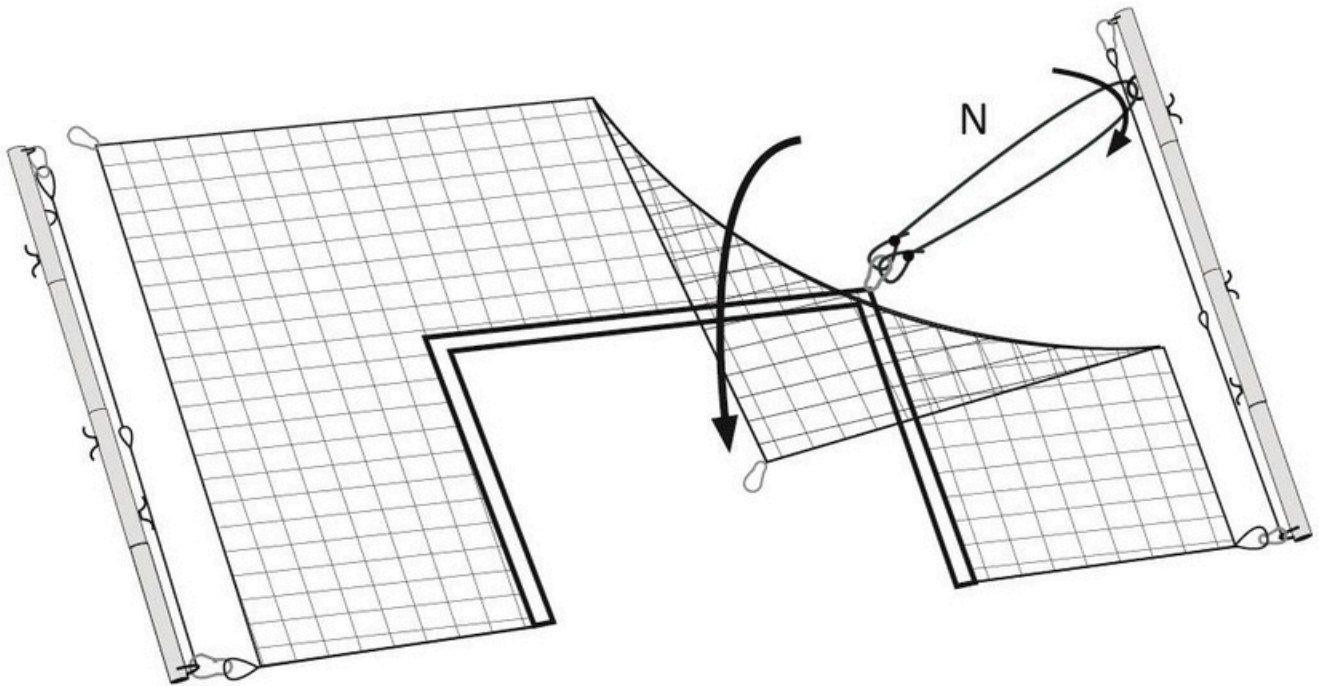

STEP 12 – Fold down the top left corner of the net. Loop the lock end of the Crossbar rope over the lowest cleat (which should be on the inside of the pole). Then pass the other end of the rope through the pole loop, and fasten to the goalmouth carabiner top left. Fold the net back.

Part M

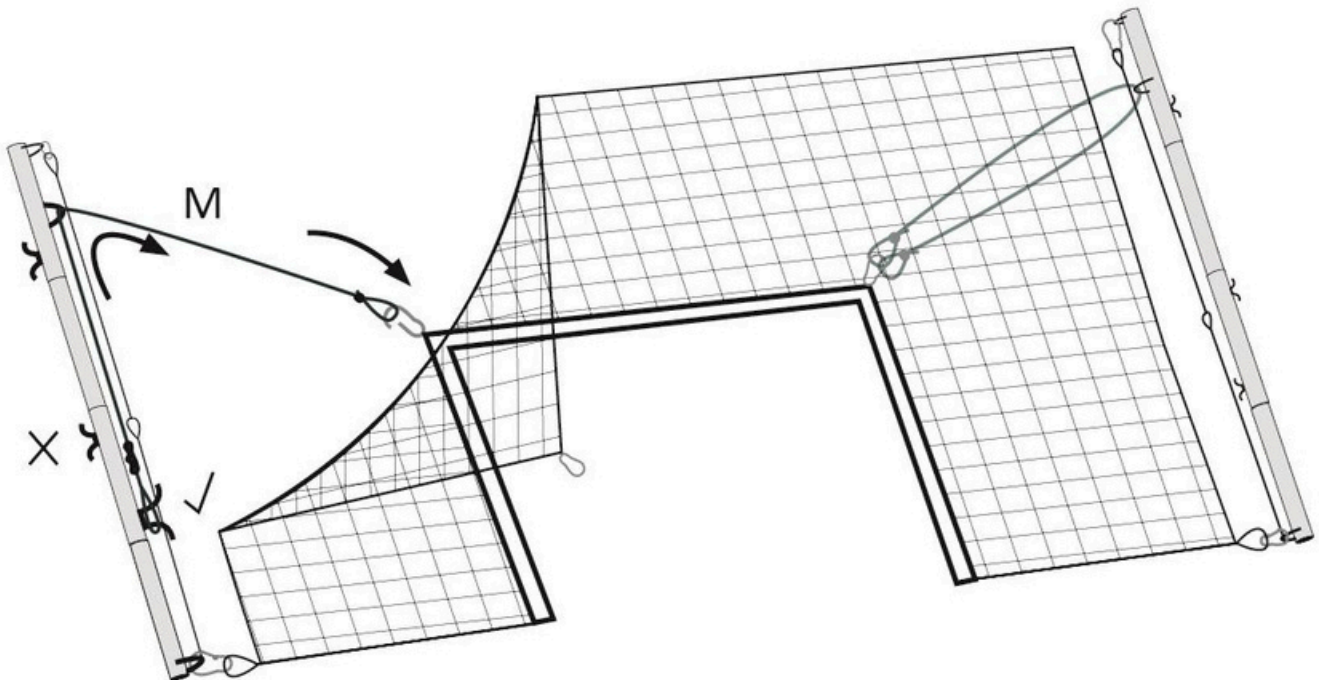

STEP 13 – Attach the Net to the side Ropes and Bungee (not to the poles!) using the Carbine Hooks

Parts K x 10

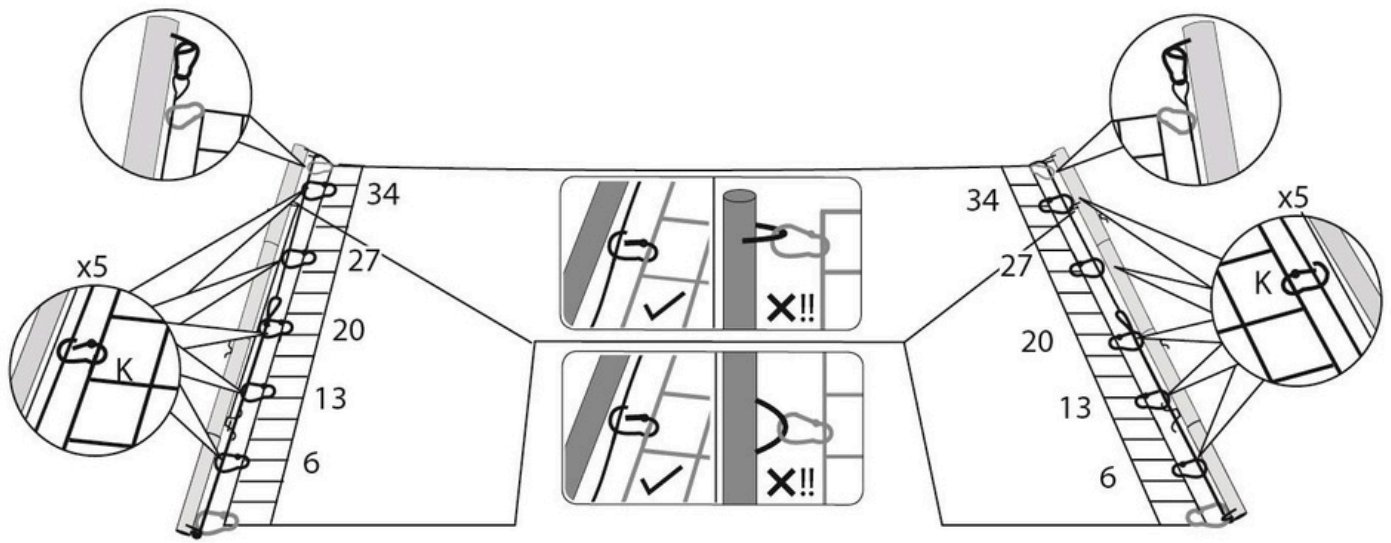

STEP 14 – Weave the Topwire bungee across the net top; and fasten each end to the pole loop with a carabiner.

Part G, Part K x 2

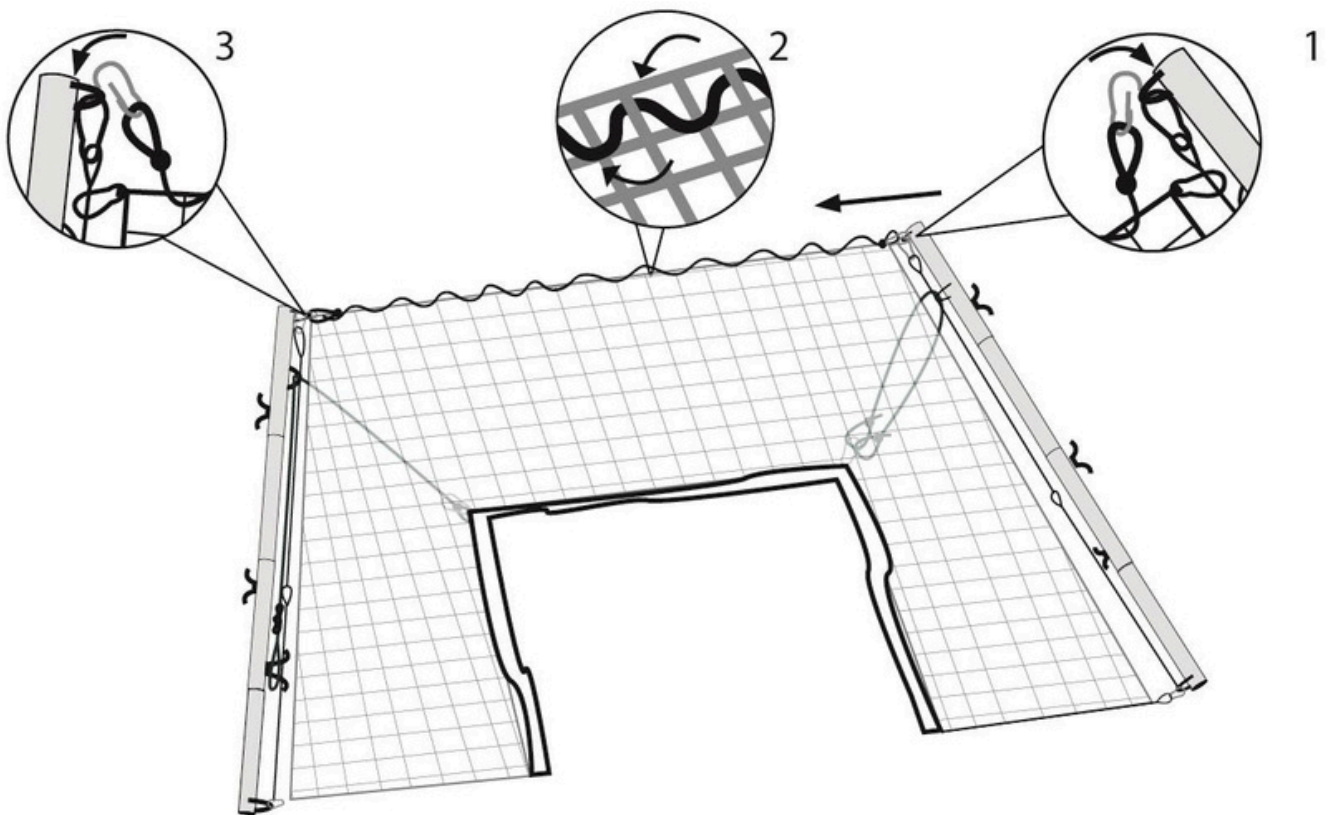

NOTE – The Topwire Bungee is significantly shorter than the net width, and so the top of the poles will pull together and the net will bunch. This is OK.

STEP 15 – At the right side, pick up the loose ends of the 3 longer outer guy ropes (F2 in Step 6). Loop them over the top cleat on the pole.

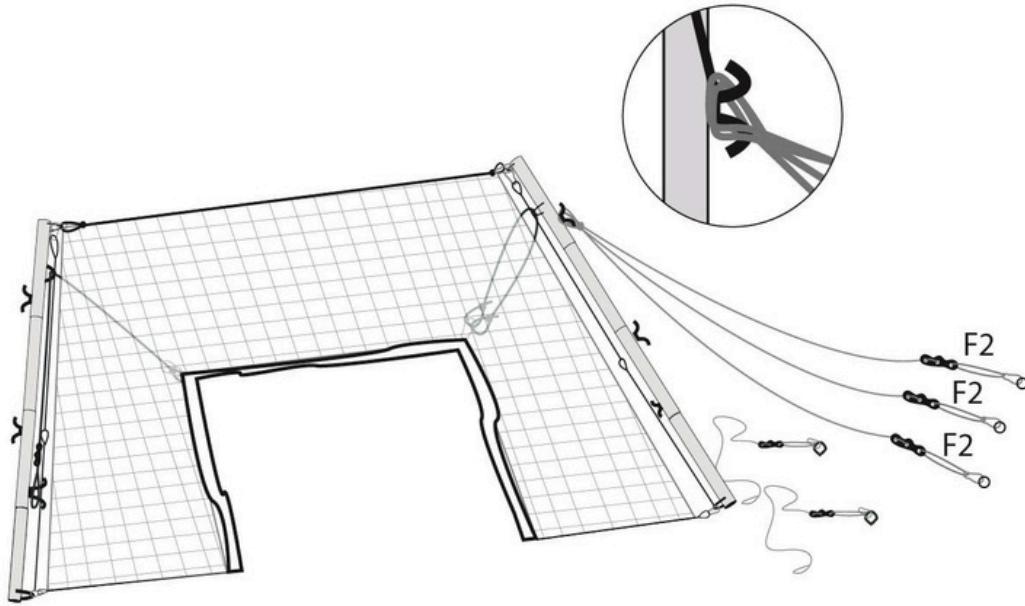

STEP 16 – Stand-up the Pole at the right-side of the Net. Attach the 2 remaining guy ropes. Then adjust all guy ropes until the pole is vertical.

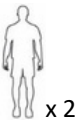

First...

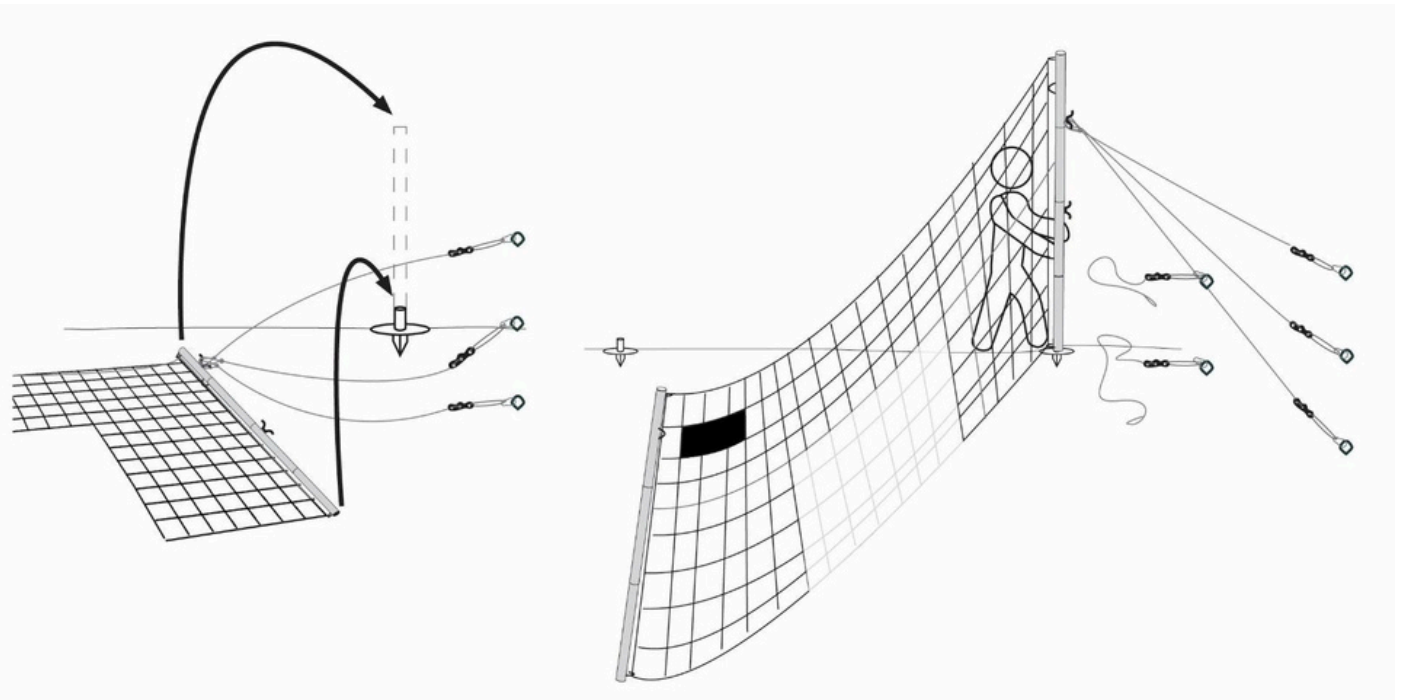

Then other 2 ropes added. Pole straight. All ropes tight .

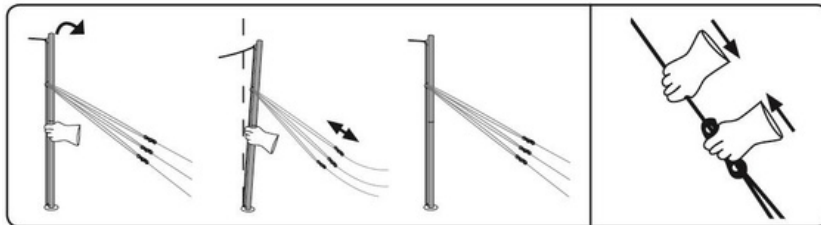
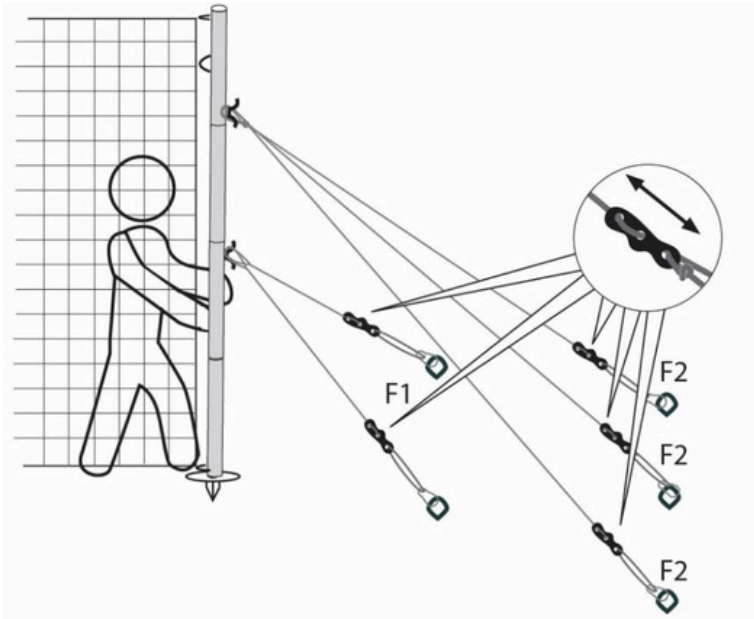

TIP – It’s hard to move the locks on tight ropes. Person 2 should first push/pull the pole outwards very slightly, to loosen ropes and make adjusting lock easier. Then adjust locks using 2 hands as pictured.

STEP 17 – Hook 3 guy ropes on to top cleat. Stand up Left Pole. Attach remaining 2 guy ropes. Adjust all ropes so pole straight.

2 people are required to pull back and plant the left pole, due to the tight topwire bungee

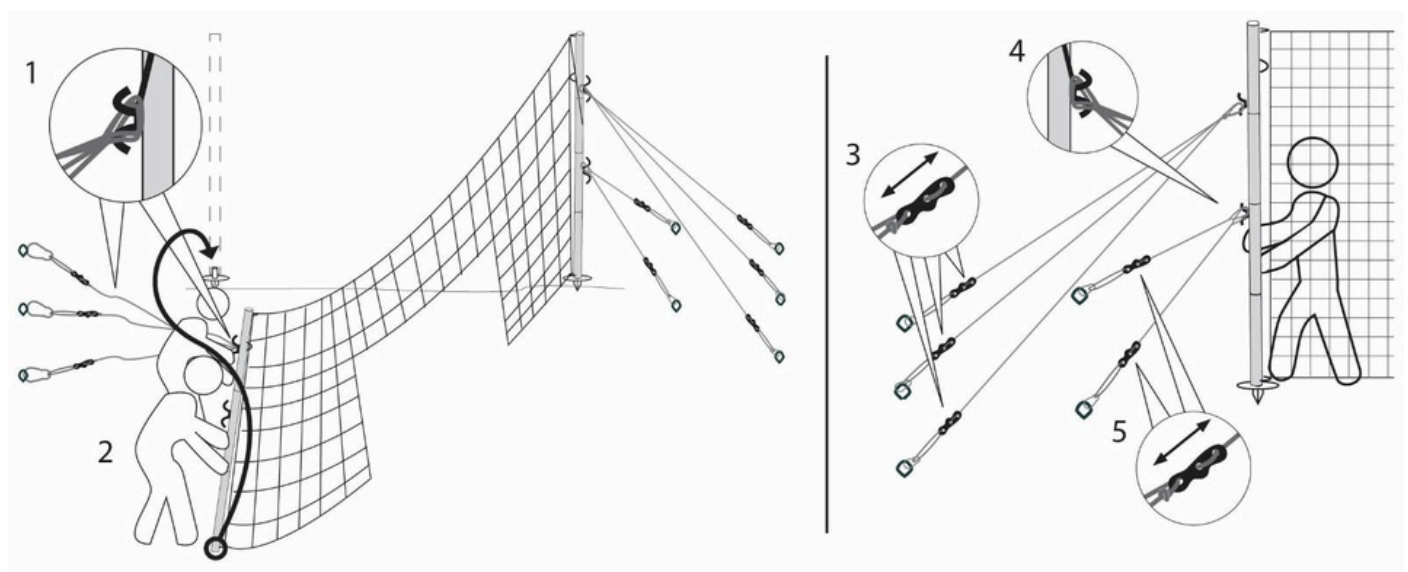

Pole straight. All ropes tight.

STEP 18 – Hook bottom of the goalposts onto the Pegs (H) inserted in step 5.

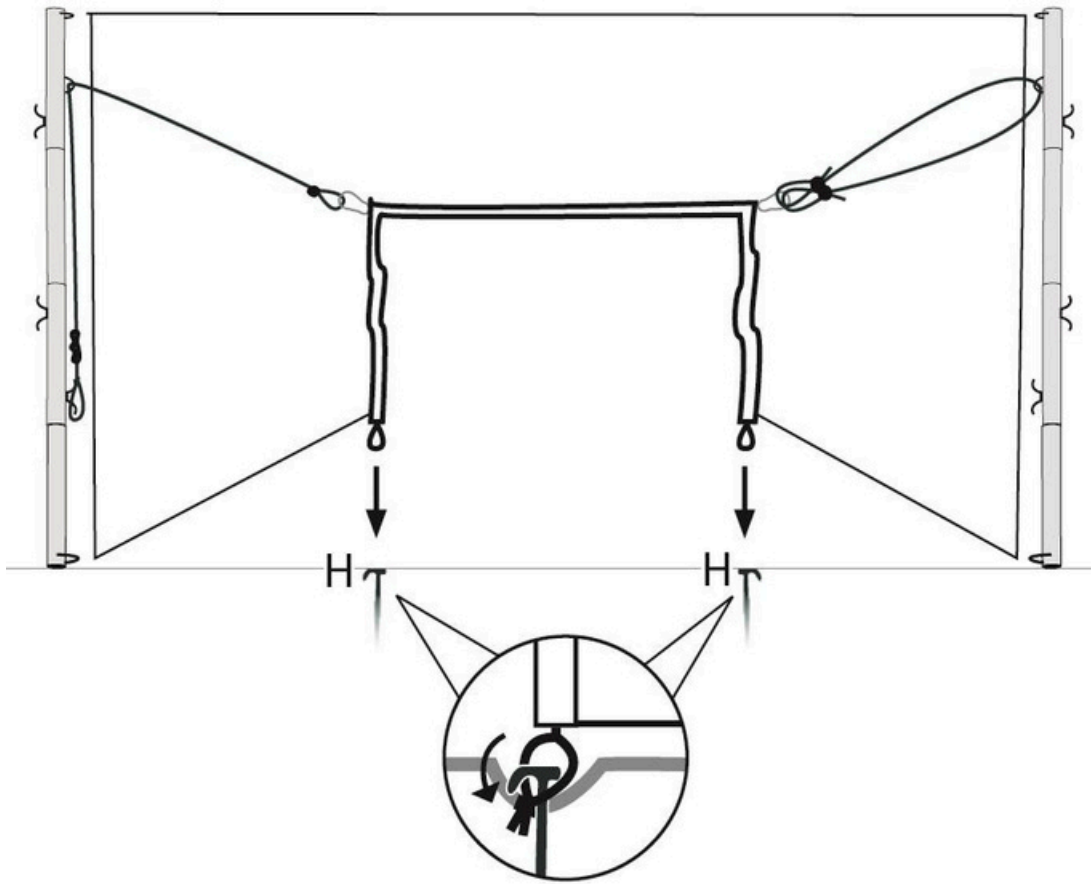

STEP 19 – If the goalmouth is not straight, then adjust lock on Crossbar Rope (M) on Left pole.

Because of tension, first pull-down loop and remove from cleat, before adjusting lock. Don't let go.

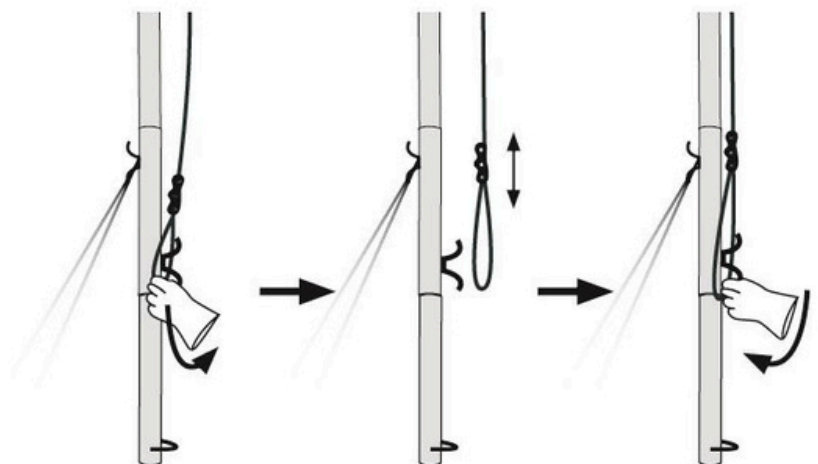
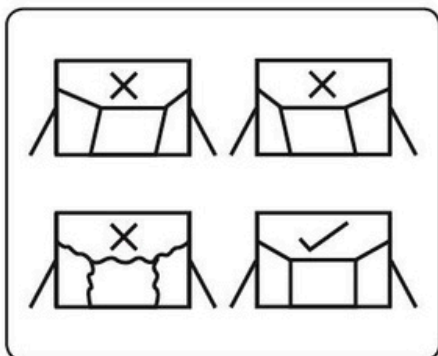

STEP 20 – Create the 3D goal by inserting Pegs and hooking the goal onto them.

Parts H X 2

Dig hole with spare H

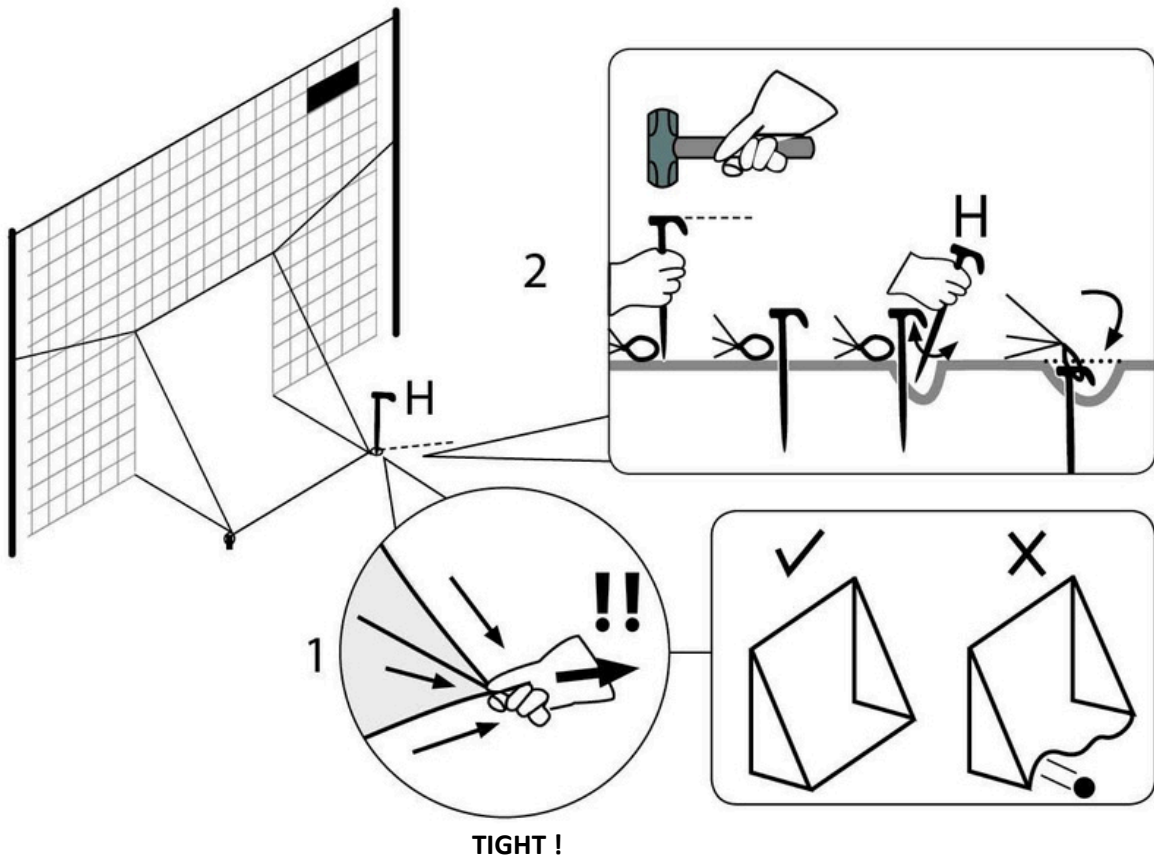
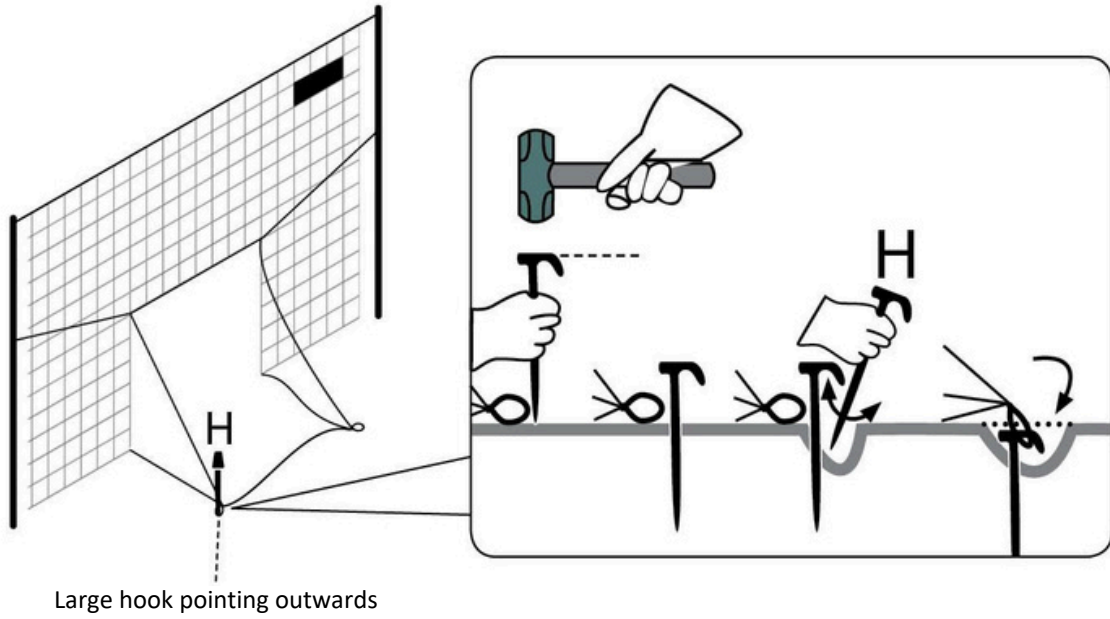

STEP 21 – Fit the Net Back Bungee to help stop balls escaping under.

PART O x 1, K x 2

1. Use carabiner to attach end of Ball Escape Bungee to the bungee loop on the corner of net.
2. Weave Ball Escape Bungee in and out of every square to right side. It will need stretching by the end.
3. Repeat 1 at right side.

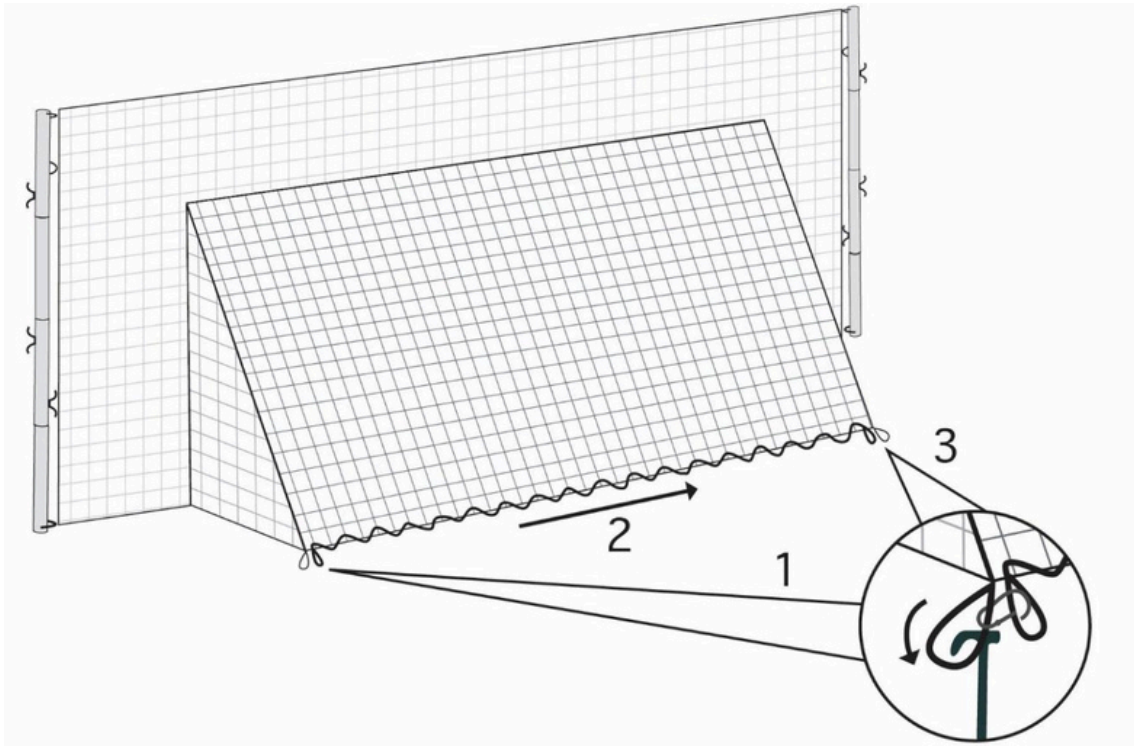

22. WARNING – Beware of Foxes nibbling the net and Lawnmowers chopping it. Raise the net at night and when not in use.

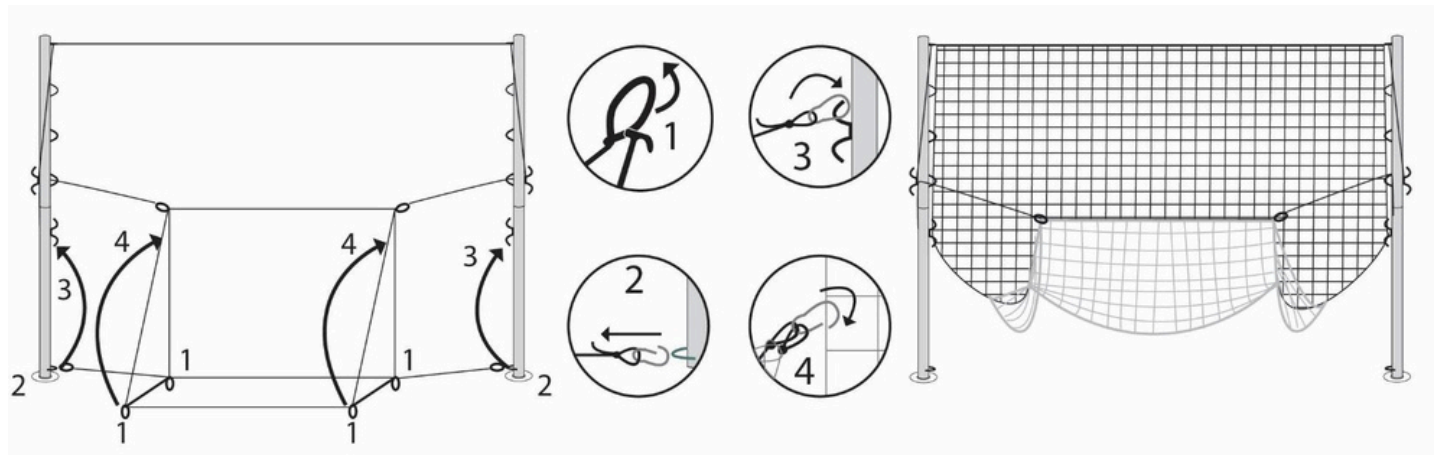
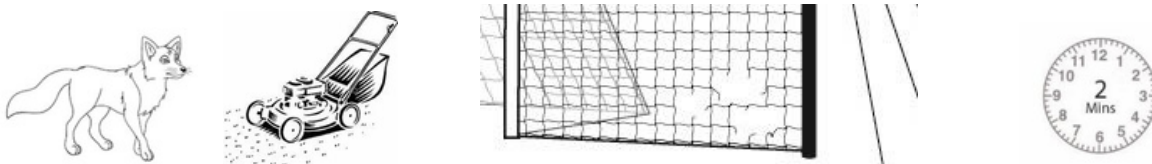

Bubble 4 – ensure carabiner stays attached to both bungee loops

Ground Too Hard for Red Pegs?

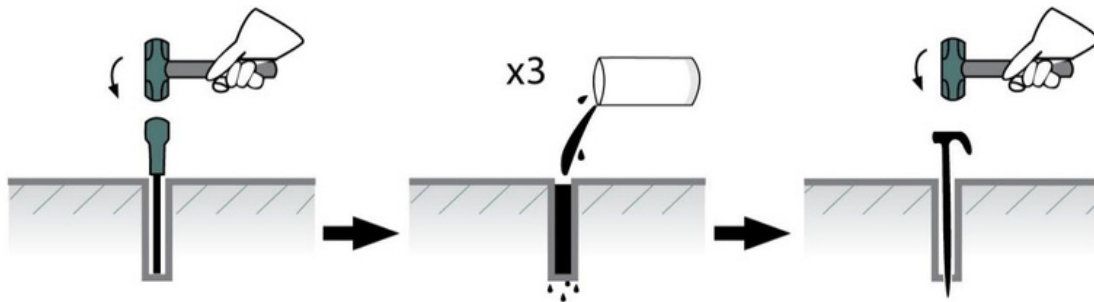

Create a guide hole with a rod thinner than the peg. Add water and leave to soften soil.

Soft Ground – Anchors pull out?

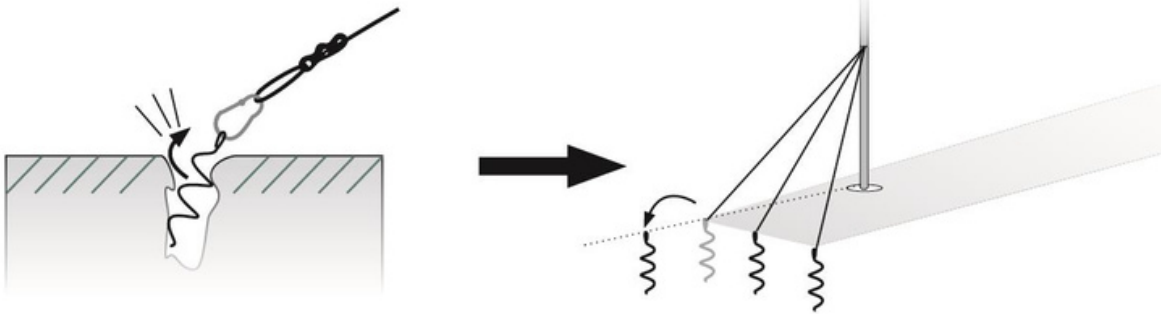

1. Move anchor in same line from pole.
- Or
2. Contact us and purchase special spiral anchors (already included on Full Size)

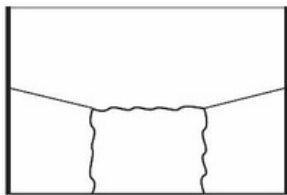

Goalmouth loose – see Step 19
Also check pole spikes not sinking – see next page

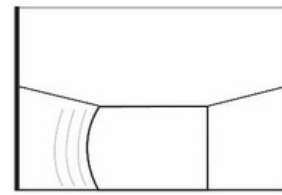

Goalpost arched
Check Step 1 distances; Step 19 tightness

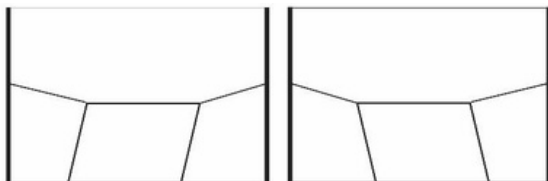

Goalposts both leaning – see Step 19

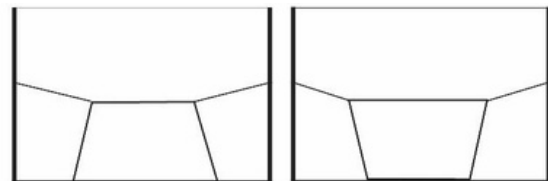

Goalposts bottom width different to top
See Step 1 – check distances

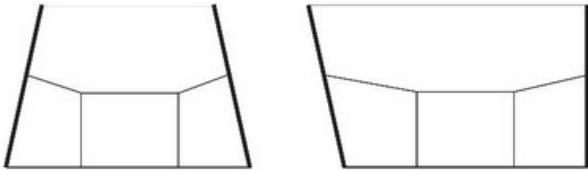

Poles not straight – see Steps 16 & 17.
Adjust guy rope locks. Or fix loose anchors.

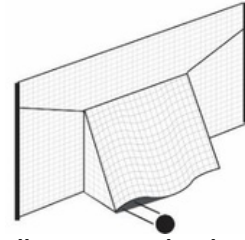

Ball escapes under the back
Check Steps 20 & 21

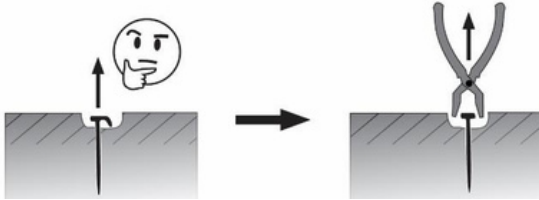

How to pull out a red peg.

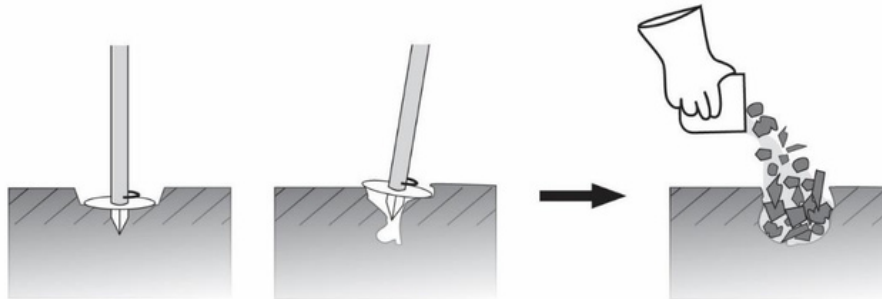

Pole spikes are sinking into soft ground. Pack hole with soil / stones for stability.

